



SISTEMA DE GESTIÓN DE COMBUSTIBLE



DISPENSADORES



KITS



BOMBAS



MEDIDORES



PISTOLAS

# CARRY

## CARACTERÍSTICAS

- FÁCIL DE INSTALAR
- SEGURA DE MOVER
- APLICACIÓN DE LARGA DURACIÓN

La bomba PIUSI CARRY es una bomba de CC de transferencia de combustible diésel diseñada para satisfacer las necesidades de aquellos que buscan una bomba portátil de larga duración y gran calidad. La CARRY 3000 está equipada con una robusta asa que facilita el transporte e incluye tubo dispensador, cables de alimentación y pistola.

### RENDIMIENTO

HASTA

**70 L/MIN**

CAUDAL

**12/24V**

TENSIÓN  
ALIMENTACIÓN

**30 MIN**

DE CICLO DE SERVICIO



CARRY PANTHER

CARRY



CARRY 3000 INLINE

### PACKAGING

| CÓDIGO    | PESO |     | PACKAGING   |          |           | N. BOX / EUROPALET |     |
|-----------|------|-----|-------------|----------|-----------|--------------------|-----|
|           | KG   | LBS | MM          | PULGADAS | UDS./CAJA | ✕                  |     |
| FO022300C | 4,2  | 9,3 | 260X235X164 | -        | 1         | 84                 | 120 |
| FO022400C | 4,2  | 9,3 | 260X235X164 | -        | 1         | 84                 | 120 |
| FO0223260 | 4,2  | 9,3 | 260X235X164 | -        | 1         | 84                 | 120 |
| FO0224240 | 4,2  | 9,3 | 260X235X164 | -        | 1         | 84                 | 120 |
| FO034004B | 4,2  | 9,3 | 260X235X164 | -        | 1         | 84                 | 120 |
| FO034104C | 4,2  | 9,3 | 260X235X164 | -        | 1         | 84                 | 120 |



FILTRACIÓN



MONITOREO DE DEPÓSITO



ENROLLADORES DE MANGUERA



ACCESORIOS



MATERIAL PROMOCIONAL

INDEX



AIRE



ANTICONG.



AdBlue®



BIODIÉSEL



DIÉSEL



ALIMENTOS



GASOLINA



GRASA



QUEROSENO



ACEITE



AGUA



LIMPIAPARAB.

## GRÁFICO

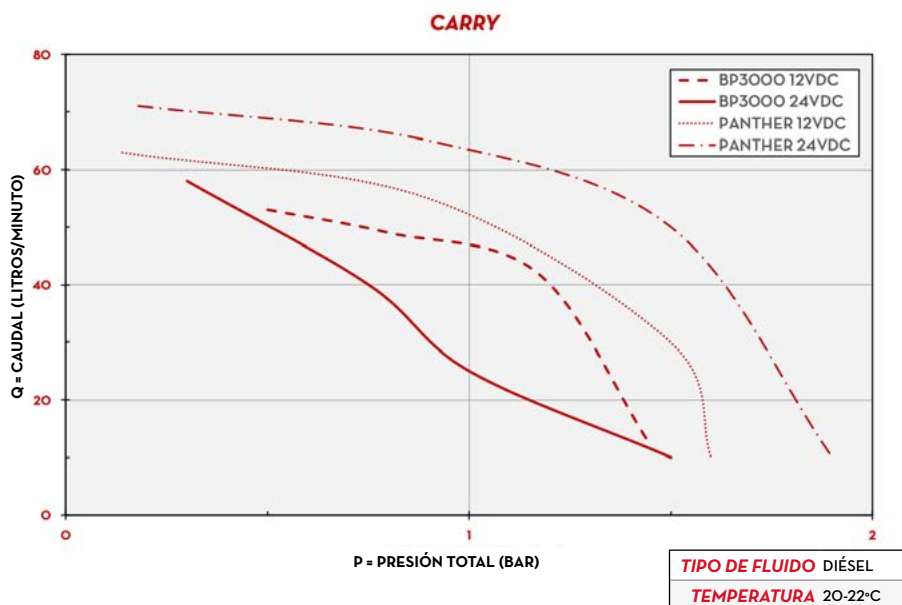

## CONTENIDO DE LA CAJA

- BOMBA CARRY
- ASA
- CABLE ELÉCTRICO CON PINZAS
- CONEXIONES
- MANUAL DE INSTRUCCIONES

## DETALLES



ASA ROBUSTA



CABLE ELÉCTRICO CON PINZAS

## DIMENSIONES

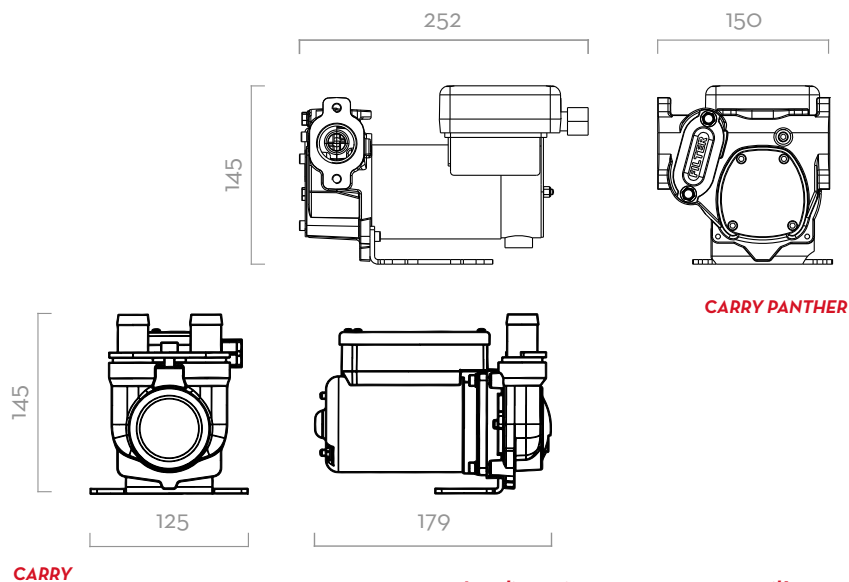

## MATERIALES

- CUERPO: HIERRO FUNDIDO
- ROTOR: ACERO SINTERIZADO
- PALETAS: RESINA ACETÁLICA
- JUNTA: NBR
- EJE: ACERO

## FICHA TÉCNICA

| CÓDIGO    | DESCRIPCIÓN             | TIPO DE FLUIDO | CAUDAL |      | TENSIÓN |                     |              | FUSIBLE<br>AMPERE | CICLO DE SERVICIO<br>MINUTO | RPM       | PRESION MAX<br>BAR | SELECTOR ON/OFF | ENTRADA/SALIDA<br>BSP |
|-----------|-------------------------|----------------|--------|------|---------|---------------------|--------------|-------------------|-----------------------------|-----------|--------------------|-----------------|-----------------------|
|           |                         |                | L/MIN  | GPM  | VOLT CC | POTENCIA/<br>VATIOS | AMP.<br>MÁX. |                   |                             |           |                    |                 |                       |
| FOO22300C | CARRY 3000 12V          | D              | 50     | 13   | 12      | 300                 | 24           | 25                | 30                          | 2900      | 1,5                | SÍ              | 3/4"                  |
| FOO22400C | CARRY 3000 24V / 12V    | D              | 50/30  | 13/6 | 24/12   | 310/80              | 13/6,5       | 15                | 30                          | 2900/1500 | 1,5                | SÍ              | 3/4"                  |
| FOO223260 | CARRY 3000 INLINE 12V   | D              | 50     | 13   | 12      | 300                 | 24           | 25                | 30                          | 2900      | 1,5                | SÍ              | 3/4"                  |
| FOO224240 | CARRY 3000 INLINE 24V   | D              | 50/30  | 13/6 | 24/12   | 310/80              | 24           | 15                | 30                          | 2900/1500 | 1,5                | SÍ              | 3/4"                  |
| FOO34004B | CARRY PANTHER 12V       | D              | 56     | 15   | 12      | 420                 | 13/6,5       | 40                | 30                          | 2900      | -                  | SÍ              | 1"                    |
| FOO34104C | CARRY PANTHER 12V / 24V | D              | 35/70  | 9/18 | 24/12   | 600/200             | 13/6,5       | 30                | 30                          | 3500/1800 | -                  | SÍ              | 1"                    |

# CARRY

PORTÁTIL