

Submersible pump for waste water with solids in suspension, grinder system

Applications

Evacuation, transfer and emptying of waste water with solids in suspension.

Materials

Pump and impeller in cast iron.
Grinder blade in steel.
Pump shaft in AISI 420.
Mechanical seal.
O-rings in NBR/EPDM.

Equipment

90° elbow included.
Model MA with float switch and 10m of cable without plug.
Model M/T without float switch and 10m of cable without plug.
External capacitor with capacitor box included.

Motor

Asynchronous 2 poles.
IP68 protection.
Continuous operation.
Class F insulation.
Single phase motor with built-in thermal protection.

Limitations

Maximum water temperature 40 °C.
Maximum submersion 7m.



Model MA



Model M/T

Hydraulic performance table

Model	I [A]		P1 [kW]		P2		c [μF]	l/min m³/h	25	50	100	150	200	250	Code		
	1~ 230V	3~ 400V	1~	3~	[kW]	[HP]			1,5	3,0	6,0	9,0	12	15	1~230V (Model M)	1~230V (Model MA)	3~400V (Model T)
Draincor	6,4	2,6	1,4	1,4	0,9	1,2	16/50	mwc	17	15	13	10	7	5	00213497	00213498	00096617

Performance curve at 2900 rpm

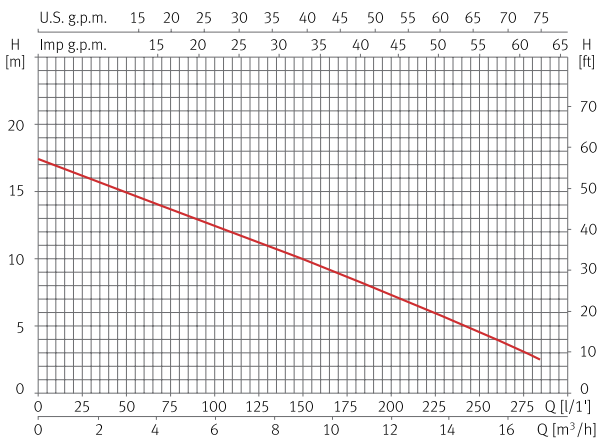

Dimension and weight

Model	A	B	C/K	D	E	F	G	H/I	J	L/M	Kg
Draincor	437	338	110	219	62	95	49	98	134	55	25

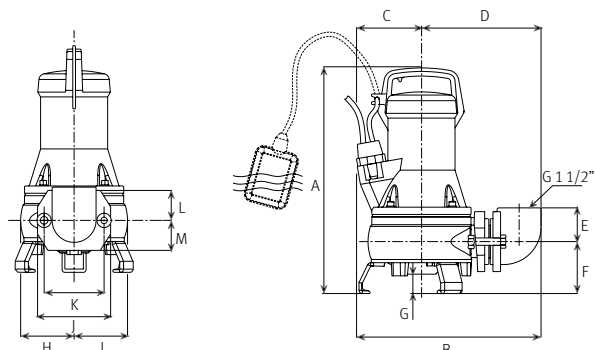

Dimension stationary version

A	B	C	D	E	F	G	H	I	J	K	L	M
388	353	110	168	60	112	60	52	8	12	51	Ø10	24

N	O	P	Q	R	S	T	U	V	W	X	Y	Z
209	Ø25	85	Ø10	98	98	120	94	12	40	13	32	60

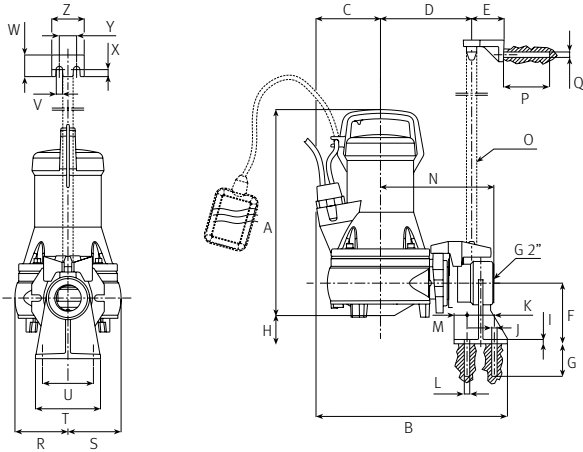

Stationary installation kit for Draincor



Support base for automatic anchoring



Clamping flange



Upper anchoring on guide tube

Kit	Code
DR1	00100527