

Prefabricated lifting station for wastewater in compliance with EN 12050-1&2 standard

DOUBLEBOX PLUS Series



MARKET SECTORS

DOMESTIC.

APPLICATIONS

- Suitable for delivering gray water and wastewater to main sewer lines located at a higher level, or where gravity drainage is not possible.

SPECIFICATIONS

- The standard station is equipped with:
 - polyethylene **basin** with a capacity of 550 litres, equipped with two threaded pedestrian covers (100 kg max).
 - **Cable glands** for power supply cables (and floats).
 - 2x Rp 1 1/2 or Rp 2 **delivery pipes** with fast connections and ring nuts for easy disassembly of the pumps or with sliding device.
 - **8 fast connections:**
 - 4 x DN110 for inlet,
 - 2 x DN50 for ventilation and
 - 2 x DN65 for cable connection.
 - **1 x DN50** fast connection for the manual pump.
 - 2x **DOMO** or **DL submersible pumps**, vortex, channel impeller type or with grinder device.
 - QDR2 **control panel** for three-phase versions.
 - **3 rubber seals:**
 - 1 x DN110, 1 x DN50 and
 - 1 x DN65 mm.
- Versions with **vortex impeller** or with **grinder device** suitable for:
 - clean water, effluent, sewage containing suspended solids and fibres.
- Versions with **single or twin channel impeller** suitable for:
 - clean water, effluent, sewage containing suspended solids but not containing fibres.
- Special versions equipped with delivery pipes, ball check valve and gate valve.
- Special versions equipped with sliding device and non-return ball valve.
- **Doublebox plus** can be installed on the floor or buried in a suitable structure following instructions in the "Instructions and Operative Manual".
- **Easy installation:**
 - installation is quick and easy:
 - for the single-phase versions you just connect the pipes and the electrical cables; for the three-phase versions you also need to connect the control panel.
 - The new **Doublebox plus** is provided with side handles for ease of handling.
 - Pre-installed delivery pump and unions.
- **Ecological solution:**
 - tank made from 100% recyclable polyethylene.
 - Airtight anti-pollution tank, pursuant to European standard EN 12050.
- **Easy maintenance and repair.**
 - Tried and tested pump technology.
 - Pump quick and easy to remove thanks to the ring nut located near the cover.

ACCESSORIES

- Available accessories:
 - Ball check valves.
 - Alarm kit.
 - Manual pump + seal.
 - Seals kit.

IDENTIFICATION CODE

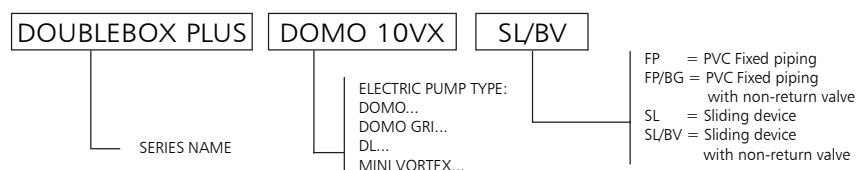

EXAMPLE : DOUBLEBOX PLUS DOMO 10VX SL/BV
Lifting station DOUBLEBOX PLUS series with DOMO 10VX submersible electric pump with sliding device and non-return valve.

DOUBLEBOX PLUS SERIES CHART

DOUBLEBOX PLUS		CHARACTERISTICS					FEATURED COMPONENTS			VERSIONS																												
		kW	HP	Q max (l/min)	H max (m)	Impeller type	Control panel	Float pre-assembled on pump	Float (10 m cable)	Standard with ring nut	Ring nut, non-return valve and gate valve	Standard	With non-return valve																									
DOUBLEBOX PLUS DATA REFERS TO 2 PUMPS RUNNING SIMULTANEOUSLY		FIXED PVC PIPE FITTINGS											SINGLE-PHASE	2x0,55	2x0,75	640	10,7	TWIN CHANNEL		X		X	X															
														2x0,55	2x0,75	520	9,1	VORTEX		X		X	X															
														2x0,75	2x1	1000	10,1	TWIN CHANNEL		X		X	X															
														2x0,75	2x1	800	7,7	VORTEX		X		X	X															
														2x1,1	2x1,5	1200	12,7	TWIN CHANNEL		X		X	X															
														2x1,1	2x1,5	900	9,1	VORTEX		X		X	X															
														2x1,1	2x1,5	220	25	GRINDER		X		X	X															
													2x0,55	2x0,75	640	10,7	TWIN CHANNEL	X		X	X	X																
													2x0,55	2x0,75	520	9,1	VORTEX	X		X	X	X																
													2x0,75	2x1	1000	10,1	TWIN CHANNEL	X		X	X	X																
													2x0,75	2x1	800	7,7	VORTEX	X		X	X	X																
													2x1,1	2x1,5	1200	12,7	TWIN CHANNEL	X		X	X	X																
													2x1,1	2x1,5	900	9,1	VORTEX	X		X	X	X																
													2x1,5	2x2	1340	14,8	TWIN CHANNEL	X		X	X	X																
													2x1,5	2x2	1100	11	VORTEX	X		X	X	X																
													2x1,1	2x1,5	220	25	GRINDER	X		X	X	X																
													DOUBLEBOX PLUS DATA REFERS TO 2 PUMPS RUNNING SIMULTANEOUSLY		LOWERING DEVICE											SINGLE-PHASE	2x0,75	2x1	1000	10,1	TWIN CHANNEL		X				X	X
																											2x0,75	2x1	800	7,7	VORTEX		X				X	X
																											2x1,1	2x1,5	1200	12,7	TWIN CHANNEL		X				X	X
																											2x1,1	2x1,5	900	9,1	VORTEX		X				X	X
2x1,1	2x1,5	220	25	GRINDER		X				X	X																											
2x0,75	2x1	1000	10,1	TWIN CHANNEL	X		X			X	X																											
2x0,75	2x1	800	7,7	VORTEX	X		X			X	X																											
2x1,1	2x1,5	1200	12,7	TWIN CHANNEL	X		X			X	X																											
2x1,1	2x1,5	900	9,1	VORTEX	X		X			X	X																											
2x1,5	2x2	1340	14,8	TWIN CHANNEL	X		X			X	X																											
2x1,5	2x2	1100	11	VORTEX	X		X			X	X																											
2x1,1	2x1,5	220	25	GRINDER	X		X			X	X																											
2x0,6	2x0,8	700	7,6	SINGLE CHANNEL		X				X	X																											
2x0,6	2x0,8	900	9,7	SINGLE CHANNEL		X				X	X																											
2x0,6	2x0,8	600	7,2	VORTEX		X				X	X																											
2x1,1	2x1,5	1200	18,3	SINGLE CHANNEL		X				X	X																											
2x1,1	2x1,5	1000	10,6	VORTEX		X				X	X																											
2x0,6	2x0,8	700	7,6	SINGLE CHANNEL	X		X			X	X																											
2x0,6	2x0,8	900	9,7	SINGLE CHANNEL	X		X			X	X																											
2x0,6	2x0,8	600	7,2	VORTEX	X		X			X	X																											
2x1,1	2x1,5	1000	14,1	SINGLE CHANNEL	X		X			X	X																											
2x1,1	2x1,5	1200	18,3	SINGLE CHANNEL	X		X			X	X																											
2x1,1	2x1,5	1000	10,6	VORTEX	X		X			X	X																											
2x1,1	2x1,5	1000	8,4	VORTEX	X		X			X	X																											
2x1,5	2x2	1400	21,9	SINGLE CHANNEL	X		X			X	X																											
2x1,5	2x2	1200	13,1	VORTEX	X		X			X	X																											

dbxplus_modelli-en_c_sc

Notes

Single-phase pumps come with start capacitor, overload protection and float switch. Versions with control panel and accessories are available on request.

DOUBLEBOX PLUS WITH DOMO-DOMO VX ELECTRIC PUMPS OPERATING CHARACTERISTICS AT 50 Hz

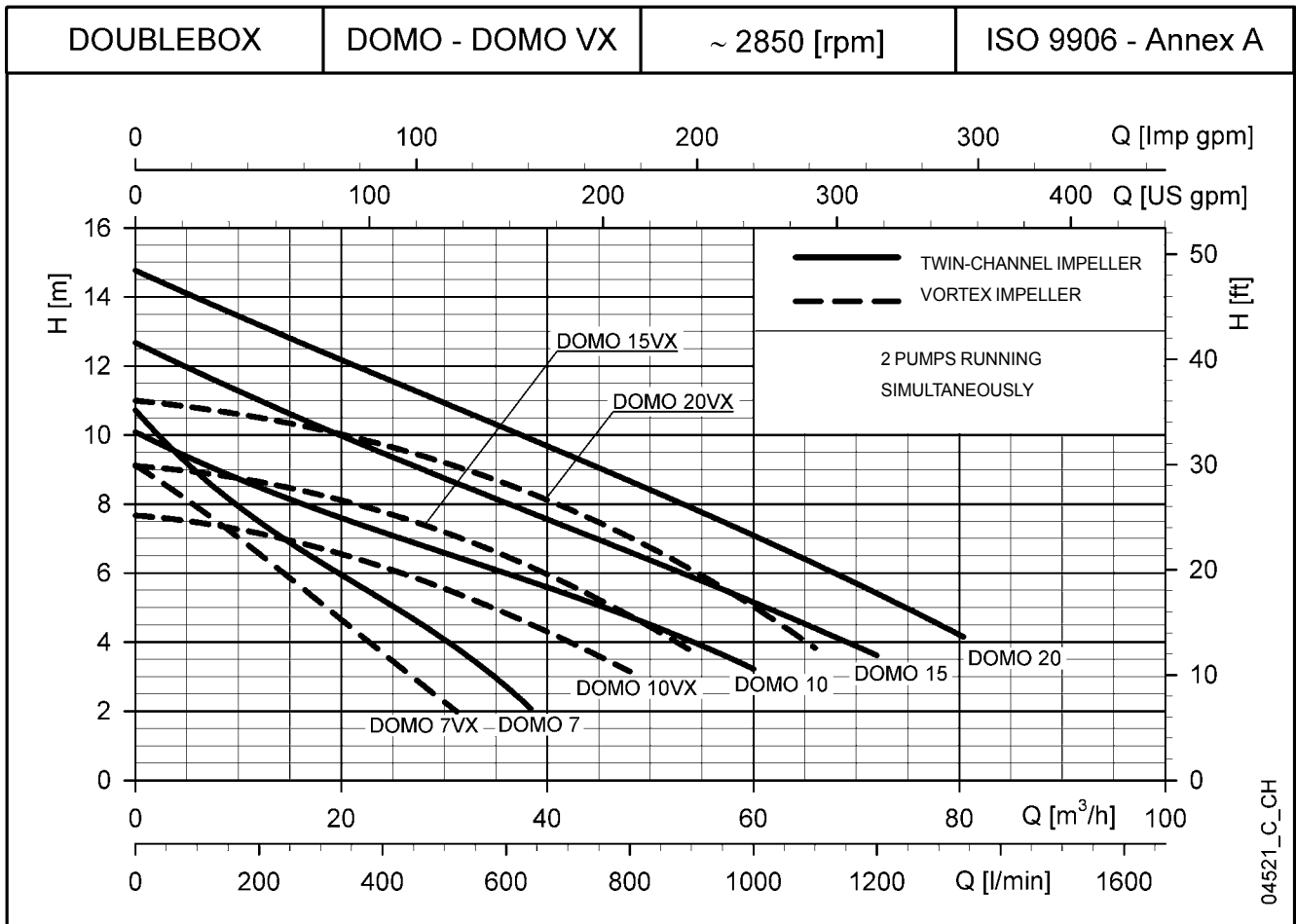

HYDRAULIC PERFORMANCE TABLE

DOMO	PUMP TYPE	RATED POWER		Q = DELIVERY												
				H = TOTAL HEAD METRES COLUMN OF WATER												
				l/min	0	100	200	300	400	500	600	640	800	1000	1200	1340
				m ³ /h	0	6	12	18	24	30	36	38,4	48	60	72	80,4
	DOMO 7(T)	2x0,55	2x0,75		10,7	8,9	7,5	6,3	5,2	4,1	2,7	2,1				
	DOMO 10(T)	2x0,75	2x1		10,1	9,2	8,5	7,8	7,2	6,6	6,0	5,8	4,7	3,2		
	DOMO 15(T)	2x1,1	2x1,5		12,7	11,8	11,0	10,2	9,5	8,8	8,0	7,8	6,6	5,2	3,6	
	DOMO 20T	2x1,5	2 x 2		14,8	14,0	13,2	12,4	11,7	10,9	10,2	9,9	8,7	7,1	5,4	4,2

DOMO VX	PUMP TYPE	RATED POWER		Q = DELIVERY												
				H = TOTAL HEAD METRES COLUMN OF WATER												
				l/min	0	160	200	300	350	400	450	520	600	800	900	1100
				m ³ /h	0	9,6	12	18	21	24	27	31,2	36	48	54	66
	DOMO 7VX(T)	2x0,55	2x0,75		9,1	7,1	6,6	5,1	4,4	3,7	3,0	2,0				
	DOMO 10VX(T)	2x0,75	2x1		7,7	7,3	7,1	6,7	6,5	6,2	5,9	5,4	4,8	3,1		
	DOMO 15VX(T)	2x1,1	2x1,5		9,1	8,8	8,6	8,3	8,0	7,8	7,5	7,1	6,5	4,8	3,7	
	DOMO 20VXT	2x1,5	2 x 2		11,0	10,6	10,5	10,2	9,9	9,7	9,5	9,1	8,6	7,0	6,1	3,8

These performances (referred to the single pump) are valid for liquids with density $\rho = 1,0 \text{ kg/dm}^3$ and kinematic viscosity $\nu = 1 \text{ mm}^2/\text{s}$. dbox_domo-domovx-2p50-en_a_th

ELECTRICAL DATA TABLE

PUMP TYPE	ABSORBED POWER*		CAPACITOR
	SINGLE-PHASE		
	kW	A	$\mu\text{F} / 450 \text{ V}$
DOMO 7	2x0,8	2x3,94	2x16
DOMO 10	2x1,14	2x5,84	2x22
DOMO 15	2x1,58	2x7,02	2x30
-	-	-	-
DOMO 7VX	2x0,79	2x3,91	2x16
DOMO 10VX	2x1,15	2x5,88	2x22
DOMO 15VX	2x1,36	2x6,11	2x30
-	-	-	-

PUMP TYPE	ABSORBED POWER*		
	THREE PHASE		
	kW	A	A
DOMO 7T	2x0,73	2x2,58	2x1,49
DOMO 10T	2x1,09	2x4,09	2x2,36
DOMO 15T	2x1,49	2x4,73	2x2,73
DOMO 20T	2x1,96	2x6,6	2x3,81
DOMO 7VXT	2x0,71	2x2,56	2x1,48
DOMO 10VXT	2x1,1	2x4,09	2x2,36
DOMO 15VXT	2x1,26	2x4,31	2x2,49
DOMO 20VXT	2x1,74	2x6,22	2x3,59

*Maximum values within operating range. dbox_domo-domovx-2p50-en_a_te

DOUBLEBOX PLUS WITH DOMO GRI ELECTRIC PUMPS OPERATING CHARACTERISTICS AT 50 Hz

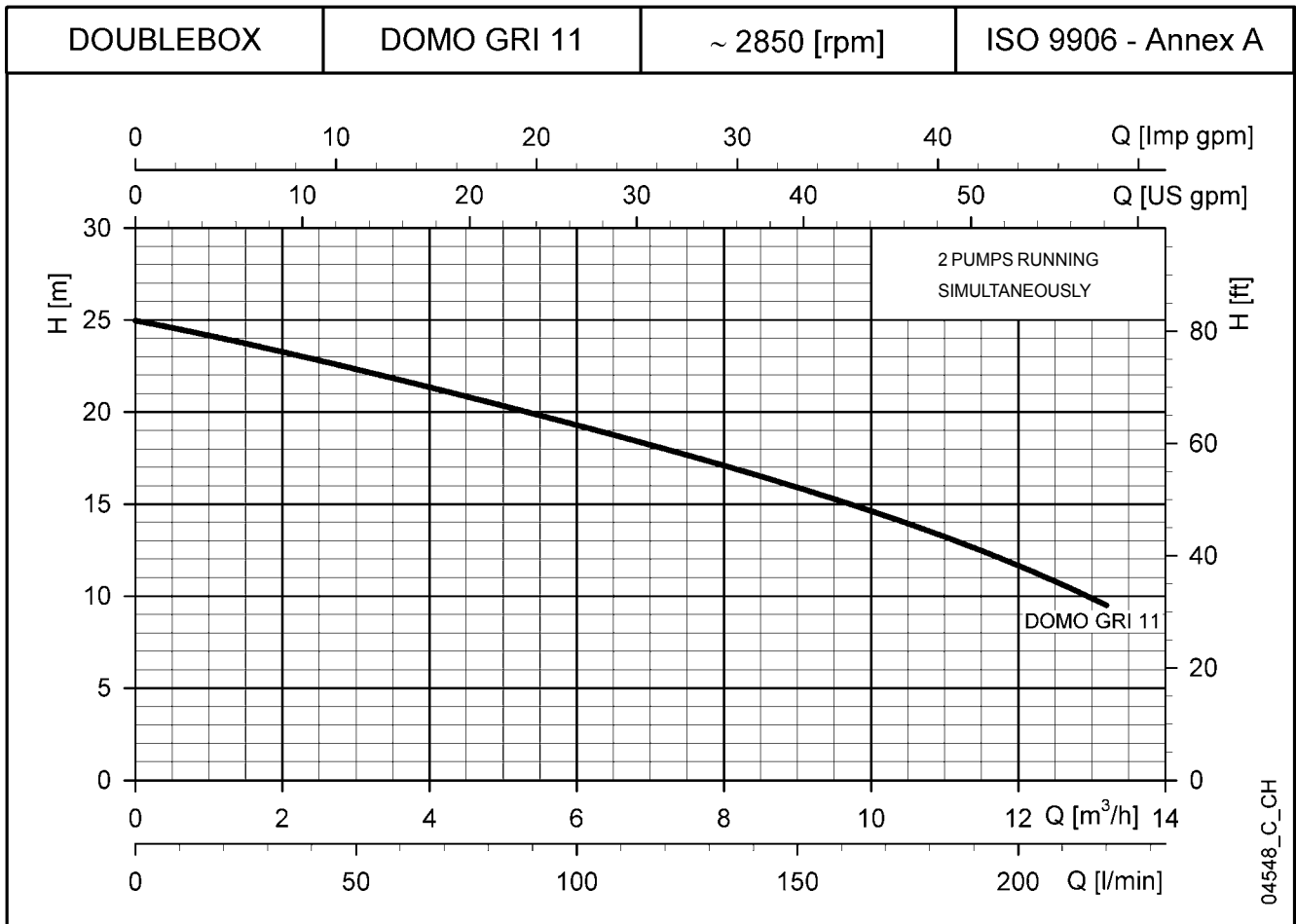

HYDRAULIC PERFORMANCE TABLE

DOMO GRI	PUMP TYPE	RATED POWER		Q = DELIVERY												
				H = TOTAL HEAD METRES COLUMN OF WATER												
				l/min	30	60	80	100	120	140	160	180	200	220		
				m ³ /h	0	1,8	3,6	4,8	6	7,2	8,4	9,6	10,8	12	13,2	
		kW	HP													
	DOMO GRI11	2x1,1	2x1,5	25,0	23,5	21,7	20,5	19,3	18,0	16,6	15,2	13,5	11,7	9,5		
	DOMO GRI11T															

These performances (referred to the single pump) are valid for liquids with density $\rho = 1,0 \text{ kg/dm}^3$ and kinematic viscosity $\nu = 1 \text{ mm}^2/\text{s}$.

dbox_domo-gri-2p50-en_b_th

ELECTRICAL DATA TABLE

PUMP TYPE	ABSORBED POWER*	ABSORBED CURRENT*	CAPACITOR
SINGLE-PHASE		220-240 V	
	kW	A	$\mu\text{F} / 450 \text{ V}$
DOMO GRI11	2x1,5	2x6,84	2x30

PUMP TYPE	ABSORBED POWER*	ABSORBED CURRENT*	ABSORBED CURRENT*
THREE-PHASE		220-240 V	380-415 V
	kW	A	A
DOMO GRI11T	2x1,39	2x4,55	2x2,63

*Maximum values within operating range.

dbox_domo-gri-2p50-en_a_te

DOUBLEBOX PLUS WITH DL-DLV ELECTRIC PUMPS OPERATING CHARACTERISTICS AT 50 Hz

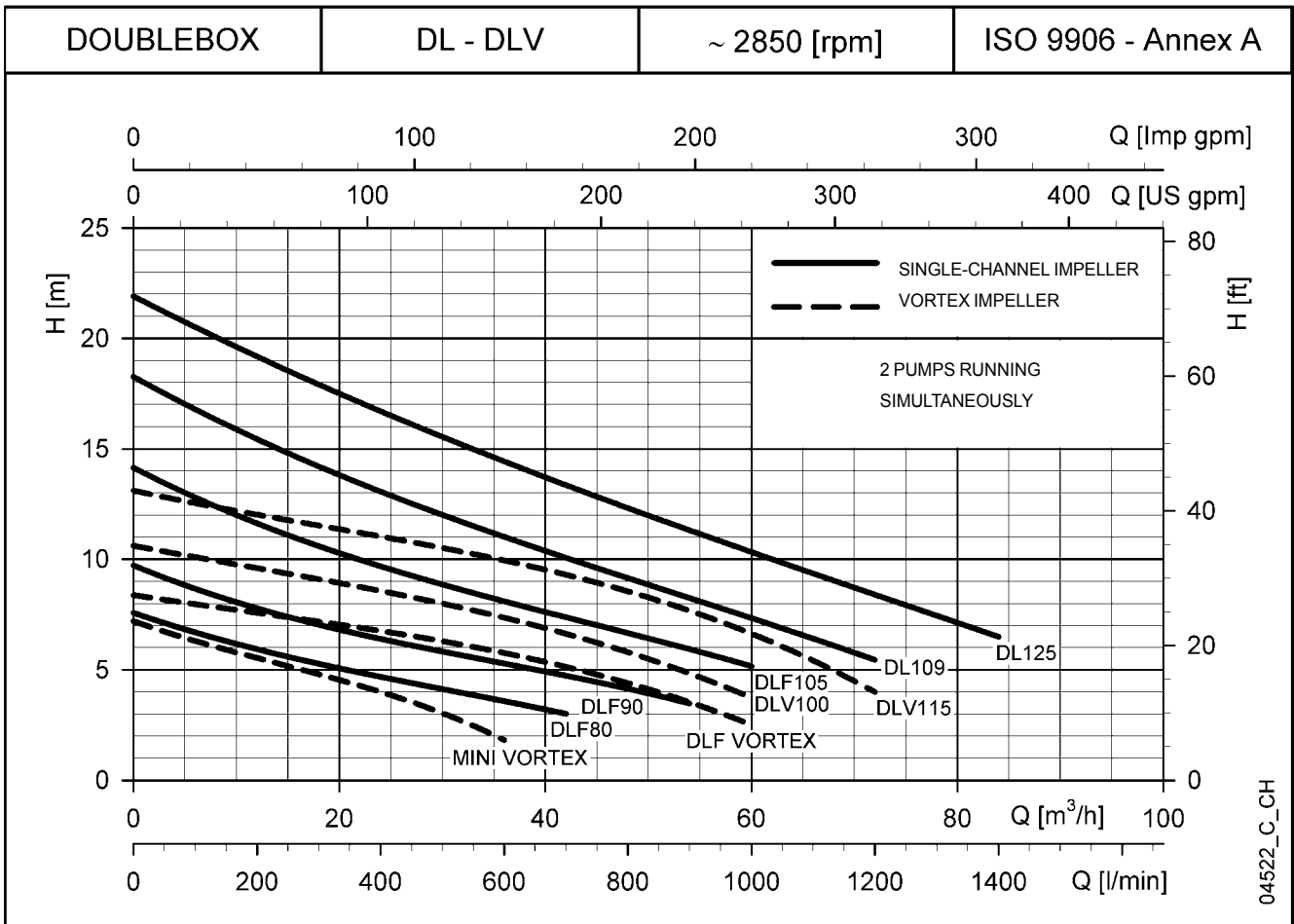

HYDRAULIC PERFORMANCE TABLE

DL	PUMP TYPE	RATED POWER		Q = DELIVERY													
				H = TOTAL HEAD METRES COLUMN OF WATER													
				l/min m³/h	0	200	300	400	500	600	700	800	900	1000	1200	1400	
		kW	HP	0	12	18	24	30	36	42	48	54	60	72	84		
	DLF(M) 80	2x0,6	2x0,8	7,6	5,9	5,3	4,7	4,1	3,6	3,0							
	DLF(M) 90	2x0,6	2x0,8	9,7	7,8	7,0	6,4	5,8	5,3	4,7	4,1	3,5					
	DLF 105	2x1,1	2x1,5	14,1	11,6	10,6	9,7	8,9	8,1	7,4	6,7	5,9	5,2				
	DL(M) 109	2x1,1	2x1,5	18,3	15,4	14,2	13,1	12,0	11,0	10,1	9,2	8,2	7,3	5,4			
	DL 125	2x1,5	2x2	21,9	19,2	17,9	16,7	15,5	14,4	13,4	12,3	11,3	10,3	8,4	6,5		

DLV	PUMP TYPE	RATED POWER		Q = DELIVERY													
				H = TOTAL HEAD METRES COLUMN OF WATER													
				l/min m³/h	0	100	200	300	400	500	600	700	800	900	1000	1200	
		kW	HP	0	6	12	18	24	30	36	42	48	54	60	72		
	MINI VORTEX(M)	2x0,6	2x0,8	7,2	6,3	5,5	4,8	4,0	3,0	1,8							
	DLF VORTEX	2x1,1	2x1,5	8,4	8,0	7,6	7,2	6,8	6,3	5,8	5,1	4,4	3,5	2,5			
	DLV(M) 100	2x1,1	2x1,5	10,6	10,1	9,6	9,1	8,6	8,0	7,4	6,6	5,8	4,8	3,7			
	DLV 115	2x1,5	2x2	13,1	12,5	12,0	11,5	11,0	10,5	9,9	9,3	8,5	7,7	6,6	4,0		

These performances (referred to the single pump) are valid for liquids with density $\rho = 1,0 \text{ kg/dm}^3$ and kinematic viscosity $\nu = 1 \text{ mm}^2/\text{s}$.

dbox_dl-dlv-2p50-en_b_th

ELECTRICAL DATA TABLE

PUMP TYPE	ABSORBED POWER*	ABSORBED CURRENT*	CAPACITOR
SINGLE-PHASE	kW	A	
DLFM 80	2x0,79	2x3,91	2x25
DLFM 90	2x0,89	2x4,27	2x25
-	-	-	-
DLM109	2x1,55	2x6,87	2x35
-	-	-	-
MINI VORTEX M	2x1,05	2x4,82	2x25
-	-	-	-
DLVM100	2x1,64	2x7,3	2x35
-	-	-	-

PUMP TYPE	ABSORBED POWER*	ABSORBED CURRENT*	ABSORBED CURRENT*
THREE-PHASE	kW	A	A
DLF 80	2x0,8	-	2x2,09
DLF 90	2x0,92	2x3,81	2x2,2
DLF 105	2x1,43	2x4,66	2x2,69
DL 109	2x1,54	2x5,44	2x3,14
DL 125	2x2,14	2x6,58	2x3,8
MINI VORTEX	2x1,1	-	2x2,36
DLF VORTEX	2x1,66	2x5,11	2x2,95
DLV 100	2x1,65	2x5,63	2x3,25
DLV 115	2x2,25	2x6,81	2x3,93

*Maximum values within operating range.

dbox_dl-dlv-2p50-en_b_te

SINGLEBOX PLUS - DOUBLEBOX PLUS SERIES DIMENSIONS AND WEIGHTS

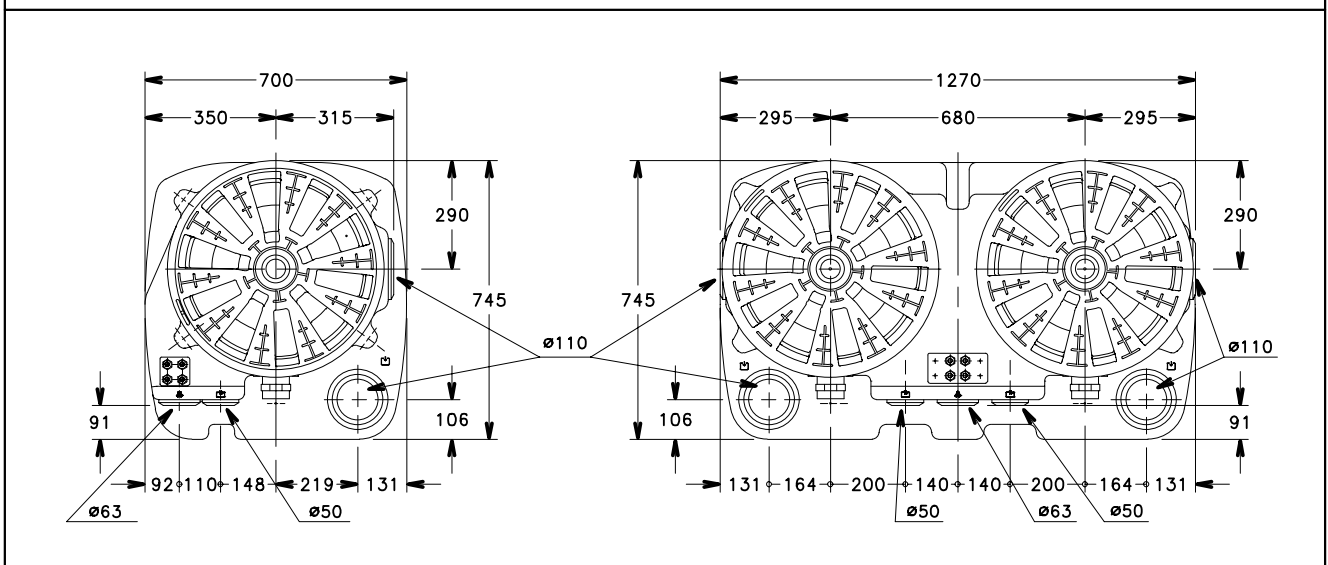
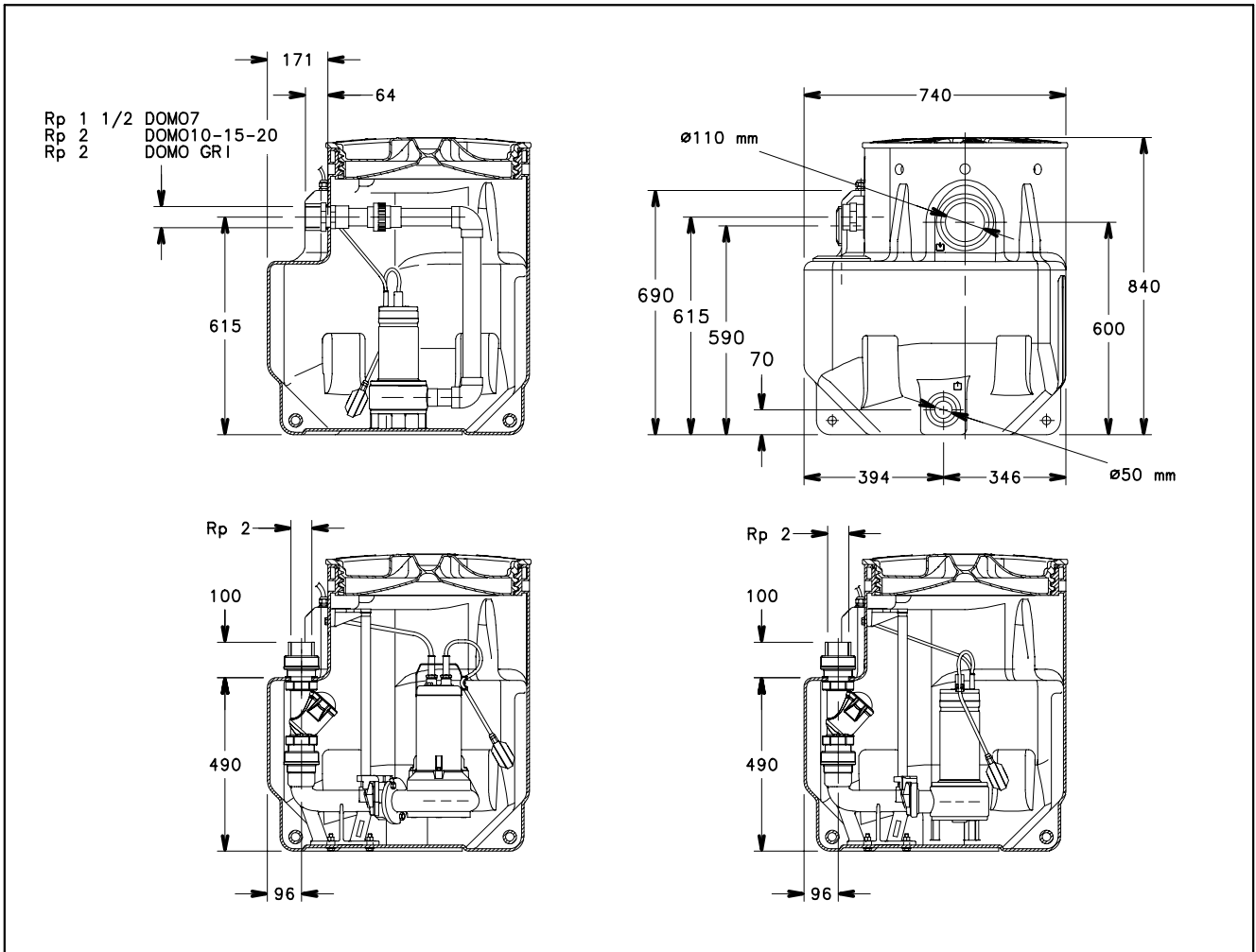

MODEL	WEIGHT (kg)			
	PVC	PVC BV	SL	SL BV
SINGLEBOX PLUS	23	27	32	36
DOUBLEBOX PLUS	44	51	62	69

sbox-dbox-en_a_td

04514_C_DD

**SINGLEBOX PLUS - DOUBLEBOX PLUS SERIES
APPLICATION EXAMPLES**

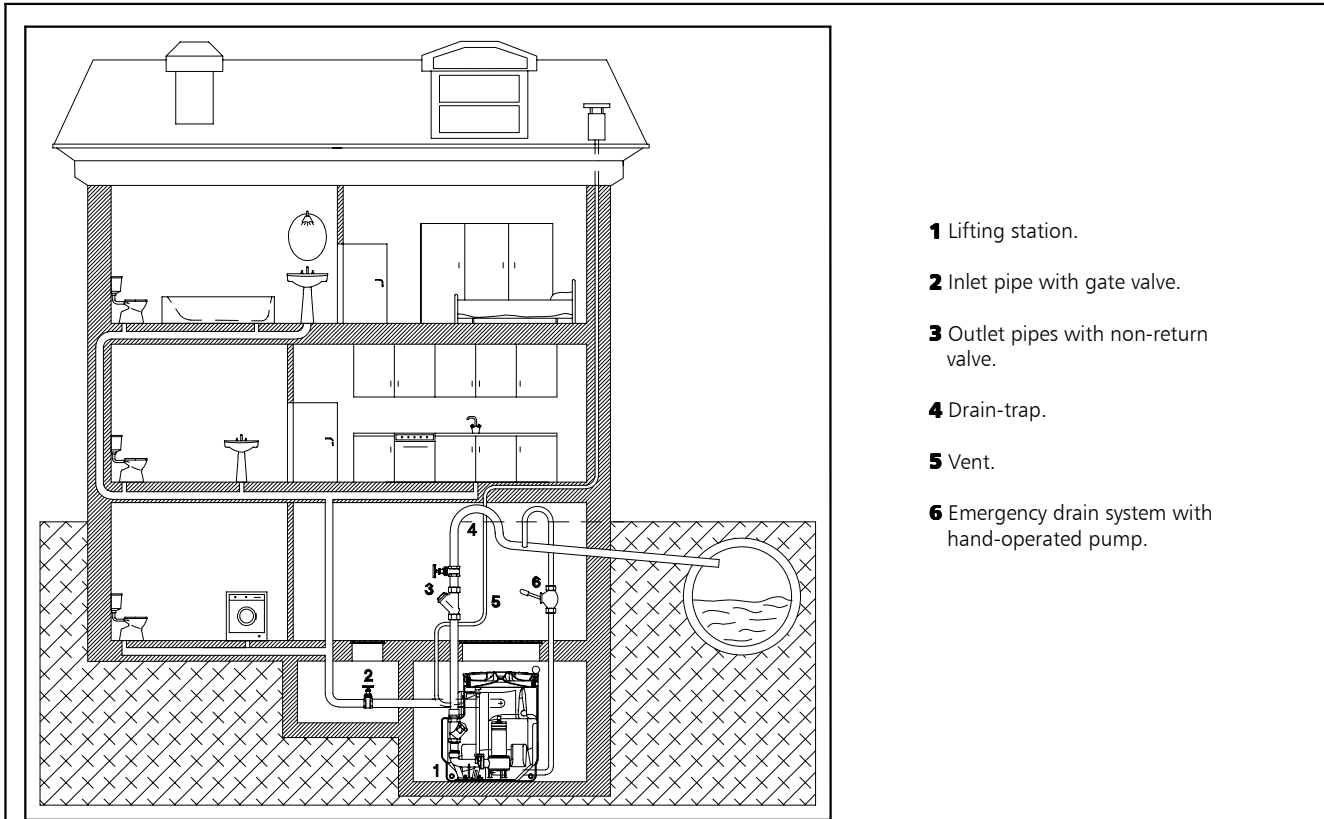

- 1** Lifting station.
- 2** Inlet pipe with gate valve.
- 3** Outlet pipes with non-return valve.
- 4** Drain-trap.
- 5** Vent.
- 6** Emergency drain system with hand-operated pump.

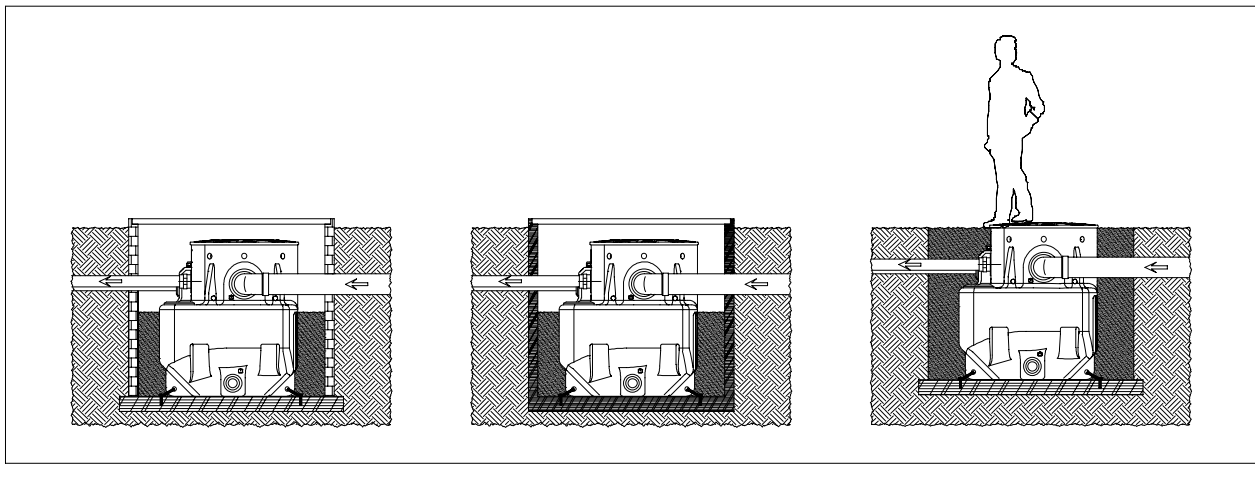
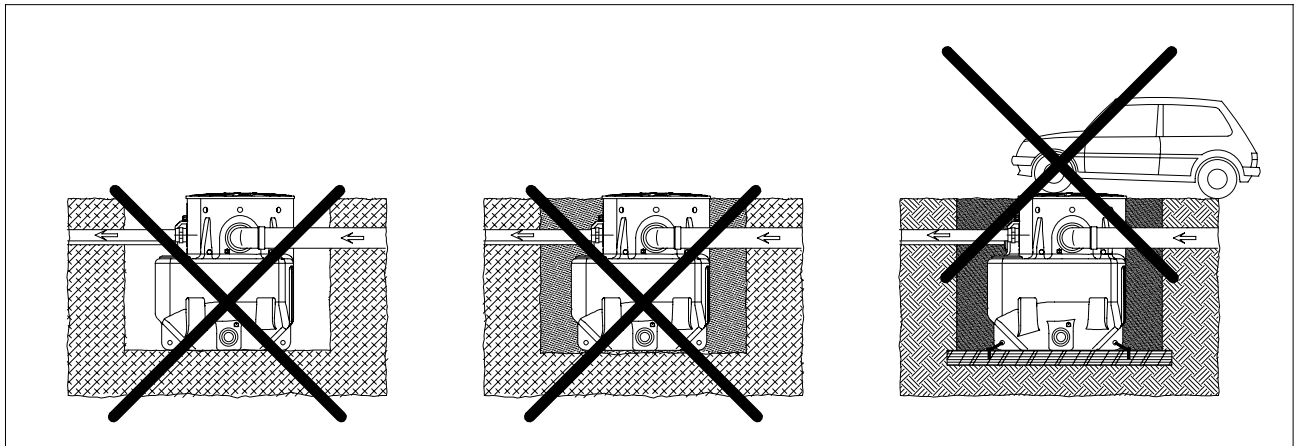

04543_B_SC

SINGLEBOX PLUS - DOUBLEBOX PLUS SERIES CERTIFICATION

MINIBOX MIDIBOX SINGLEBOX PLUS DOUBLEBOX PLUS

Station	Use
MINIBOX DOC3	Clean water
MINIBOX DOC7	Clean water
MINIBOX DOC7VX	Clean water
MIDIBOX DOC3	Clean water
MIDIBOX DOC7	Clean water
MIDIBOX DOC7T	Clean water
MIDIBOX DOC7VX	EN 12050 - 2
MIDIBOX DOC7VXT	EN 12050 - 2
MIDIBOX DOMO7	EN 12050 - 2
MIDIBOX DOMO7T	EN 12050 - 2
MIDIBOX DOMO7VX	EN 12050 - 2
MIDIBOX DOMO7VXT	EN 12050 - 2
SINGLEBOX PLUS / DOUBLEBOX PLUS DOMO 7	EN 12050 - 2
SINGLEBOX PLUS / DOUBLEBOX PLUS DOMO 7T	EN 12050 - 2
SINGLEBOX PLUS / DOUBLEBOX PLUS DOMO 7VX	EN 12050 - 2
SINGLEBOX PLUS / DOUBLEBOX PLUS DOMO 7VXT	EN 12050 - 2
SINGLEBOX PLUS / DOUBLEBOX PLUS DOMO 10	EN 12050 - 1
SINGLEBOX PLUS / DOUBLEBOX PLUS DOMO 10T	EN 12050 - 1
SINGLEBOX PLUS / DOUBLEBOX PLUS DOMO 10VX	EN 12050 - 1
SINGLEBOX PLUS / DOUBLEBOX PLUS DOMO 10VXT	EN 12050 - 1
SINGLEBOX PLUS / DOUBLEBOX PLUS DOMO 15	EN 12050 - 1
SINGLEBOX PLUS / DOUBLEBOX PLUS DOMO 15T	EN 12050 - 1
SINGLEBOX PLUS / DOUBLEBOX PLUS DOMO 15VX	EN 12050 - 1
SINGLEBOX PLUS / DOUBLEBOX PLUS DOMO 15VXT	EN 12050 - 1
SINGLEBOX PLUS / DOUBLEBOX PLUS DOMO 20T	EN 12050 - 1
SINGLEBOX PLUS / DOUBLEBOX PLUS DOMO 20VXT	EN 12050 - 1
SINGLEBOX PLUS / DOUBLEBOX PLUS DOMO GRI 11	EN 12050 - 1
SINGLEBOX PLUS / DOUBLEBOX PLUS DOMO GRI 11T	EN 12050 - 1
SINGLEBOX PLUS / DOUBLEBOX PLUS DLFM 80	EN 12050 - 2
SINGLEBOX PLUS / DOUBLEBOX PLUS DLF 80	EN 12050 - 2
SINGLEBOX PLUS / DOUBLEBOX PLUS DLFM 90	EN 12050 - 2
SINGLEBOX PLUS / DOUBLEBOX PLUS DLF 90	EN 12050 - 2
SINGLEBOX PLUS / DOUBLEBOX PLUS MINI VORTEX M	EN 12050 - 2
SINGLEBOX PLUS / DOUBLEBOX PLUS MINI VORTEX	EN 12050 - 2
SINGLEBOX PLUS / DOUBLEBOX PLUS DLF 105	EN 12050 - 2
SINGLEBOX PLUS / DOUBLEBOX PLUS DLM 109	EN 12050 - 2
SINGLEBOX PLUS / DOUBLEBOX PLUS DL 109	EN 12050 - 2
SINGLEBOX PLUS / DOUBLEBOX PLUS DLVM 100	EN 12050 - 2
SINGLEBOX PLUS / DOUBLEBOX PLUS DLV 100	EN 12050 - 2
SINGLEBOX PLUS / DOUBLEBOX PLUS DLF VORTEX	EN 12050 - 2
SINGLEBOX PLUS / DOUBLEBOX PLUS DL 125	EN 12050 - 2
SINGLEBOX PLUS / DOUBLEBOX PLUS DLV 115	EN 12050 - 2