

# INTRODUCTION

Thank you for purchasing a Honda lawn mower.

This manual covers the operation and maintenance of the Honda HRX537VYEA lawn mower.

We want to help you get the best results from your new mower and to operate it safely. This manual contains the information on how to do that; please read it carefully.

This manual should be considered a permanent part of the lawn mower and should remain with it if it is resold.

If you have a problem or questions concerning the mower, contact your supplying dealer.

We recommend that you read the warranty policy to fully understand your rights and responsibilities. The warranty policy is a separate document provided by your dealer.

Honda Power Equipment Mfg., Inc. reserves the right to make changes at any time without notice and without incurring any obligation.

No part of this publication may be reproduced without written permission.

## SAFETY MESSAGES

Pay special attention to statements preceded by the following words:

### **⚠ DANGER**

You **WILL** be **KILLED** or **SERIOUSLY HURT** if you don't follow instructions.

### **⚠ WARNING**

You **CAN** be **KILLED** or **SERIOUSLY HURT** if you don't follow instructions.

### **⚠ CAUTION**

You **CAN** be **HURT** if you don't follow instructions.

Each message tells you what the hazard is, what can happen, and what you can do to avoid or reduce injury.

### **Damage Prevention Messages**

You will also see other important messages that are preceded by the following word:

### **NOTICE**

Your lawn mower or other property can be damaged if you don't follow instructions.

The purpose of these messages is to help prevent damage to your lawn mower, other property, or the environment.

# HONDA

## OWNER'S MANUAL

(Original instructions)

**HRX537VYE**

**LAWN MOWER**



ENGLISH

FRANÇAIS

ESPAÑOL

## CONTENTS

INTRODUCTION . . . . .	1
SAFETY MESSAGES . . . . .	1
SAFETY INSTRUCTIONS . . . . .	2
COMPONENT IDENTIFICATION . . . . .	3
SET-UP . . . . .	4
CONTROLS . . . . .	5
PRE-OPERATION CHECKS . . . . .	6
OPERATION . . . . .	9
MAINTENANCE . . . . .	12
TRANSPORTING . . . . .	17
STORAGE . . . . .	18
TROUBLESHOOTING . . . . .	19
SPECIFICATIONS . . . . .	20
Honda Warranty Conditions, "EC Declaration of Conformity" CONTENT OUTLINE, Major Honda Distributor Locations . . . . .	Last page

# SAFETY INSTRUCTIONS

## ⚠ WARNING

To ensure safe operation –



- Honda lawn mowers are designed to give safe and dependable service if operated according to instructions. Read and understand the Owner's Manual before operating the mower. Failure to do so could result in personal injury or equipment damage.

- Read instructions carefully, become familiar with controls and proper use of equipment.
- Never allow children or people unfamiliar with these instructions to use the lawn mower. Local regulations may restrict the age of the operator.
- Never mow while people, especially children, or pets are nearby.
- Keep in mind that the operator or user is responsible for injuries, property damage, or hazards occurring to other people or their property.
- While mowing, always wear substantial footwear and long trousers. Do not operate the equipment when barefoot or wearing open sandals.
- Thoroughly inspect the area where the equipment is to be used, and remove all objects which may be thrown by the machine.
- Petrol is highly flammable:
  - Store fuel in containers specifically designed for this purpose.
  - Refuel outdoors only and do not smoke while refuelling.
  - Add fuel before starting the engine. Never remove the cap of the fuel tank or add petrol while the engine is running or when the engine is hot.
  - If petrol is spilled, do not attempt to start the engine, but move the machine away from the area of spillage, and avoid creating any source of ignition until the petrol vapors have dissipated.
  - Install fuel caps securely.
- Replace faulty mufflers.
- Before using, always visually inspect to see that the blades, blade bolts, and mower housing are not worn or damaged. Replace worn or damaged blades and bolts in sets to preserve balance.
- Do not operate the engine in a confined space where dangerous carbon monoxide fumes can collect.
- Mow only in daylight or good artificial light.
- Avoid operating the equipment in wet grass, where feasible.
- Mowing on slopes:
  - Always be sure of your footing on slopes.
  - Mow across slopes, never up and down.
  - Walk, never run.
  - Exercise extreme caution when changing direction on slopes.
  - Do not mow excessively steep slopes.

- Use extreme caution when pulling the lawn mower toward you.
- Stop the blades if the lawn mower has to be tilted for transporting, when crossing surfaces other than grass, and when transporting the lawn mower to and from the area to be mowed.
- Never operate the lawn mower with defective guards or shields, or without safety devices (for example, deflectors and/or grass catchers in place).
- Do not attempt to make wheel height adjustments while the machine is running.
- Do not change the engine governor setting or over-speed the engine.
- Disengage all blade and drive clutches before starting the machine.
- Start the engine carefully according to the instructions and with feet well away from the blades.
- Do not tilt the lawn mower when starting the engine.
- Do not put hands or feet near or under rotating parts. Keep clear of the discharge opening at all times.
- Never pick up or carry a lawn mower while the engine is running.
- Stop the engine and disconnect the spark plug wire:
  - Before clearing a blockage or unclogging the lawn mower.
  - Before checking, cleaning, or working on the lawn mower.
  - After striking a foreign object. Inspect the lawn mower for damage and make repairs before restarting and operating the lawn mower.
  - If lawn mower starts to vibrate abnormally, check immediately.
- Stop the engine:
  - Whenever you leave the lawn mower.
  - Before refuelling the lawn mower.
  - Before removing the grass catcher or side discharge adapter.
- Reduce the throttle setting during engine shut down, and turn the fuel valve off at the conclusion of mowing.
- Keep all nuts, bolts, and screws tight to be sure the equipment is in safe working condition.
- Never store the equipment with petrol in the tank inside a building where fumes may reach an open flame or spark.
- Allow the engine to cool before storing in any enclosure.
- To reduce the fire hazard, keep the petrol storage area, engine, muffler, and battery compartment (if applicable) free of grass, leaves, or excessive grease.
- Check the grass catcher frequently for wear or deterioration.
- Replace worn or damaged parts for safety.
- If the fuel tank has to be drained, this should be done outdoors.
- Wear eye protection.

### Disposal

To protect the environment, do not dispose of this product, battery, engine oil, etc. carelessly by leaving them in the waste. Observe the local laws and regulations or consult your authorized Honda dealer for disposal.

## SAFETY LABEL LOCATION

This label warns you of potential hazards that can cause serious injury. Carefully read meaning. If label comes off or becomes hard to read, contact your dealer for a replacement.

Letter	Meaning
A	
	<ol style="list-style-type: none"> <li>1. Read the owner's manual before using the mower.</li> <li>2. Risk of projections: Keep third persons away from the area during use.</li> <li>3. Risk of cuts. Rotating blade: Do not put hands or feet inside the blade enclosure. Disconnect the spark plug cap before performing any operation of maintenance or repairs.</li> <li>4. Do not operate without either discharge guard or grass catcher in place.</li> </ol>

B	
	<ol style="list-style-type: none"> <li>5. Read the owner's manual before using the mower.</li> <li>6. The engine emits toxic carbon monoxide. Do not run in an enclosed area.</li> <li>7. Petrol is highly flammable. Stop the engine before refueling.</li> </ol>

## PRODUCT IDENTIFICATION PLATE

Letter	Meaning
C	
	<ol style="list-style-type: none"> <li>1. Guaranteed sound power level according to Directive 2000/14/EC</li> <li>2. Conformity mark, according to EC-Directive and GOST-R conformity mark</li> <li>3. Nominal power in kilowatts</li> <li>4. Maximum engine speed</li> <li>5. Weight in kilograms</li> <li>6. Year of manufacture</li> <li>7. Serial number</li> <li>8. Model</li> <li>9. Manufacturer's name and address and authorized representative</li> </ol>

Record the frame and engine serial numbers in the space below. You will need these numbers when ordering parts and when making technical or warranty inquiries.

Frame serial number: \_\_\_\_\_

Engine serial number: \_\_\_\_\_

Date of purchase: \_\_\_\_ / \_\_\_\_ / \_\_\_\_

## COMPONENT IDENTIFICATION

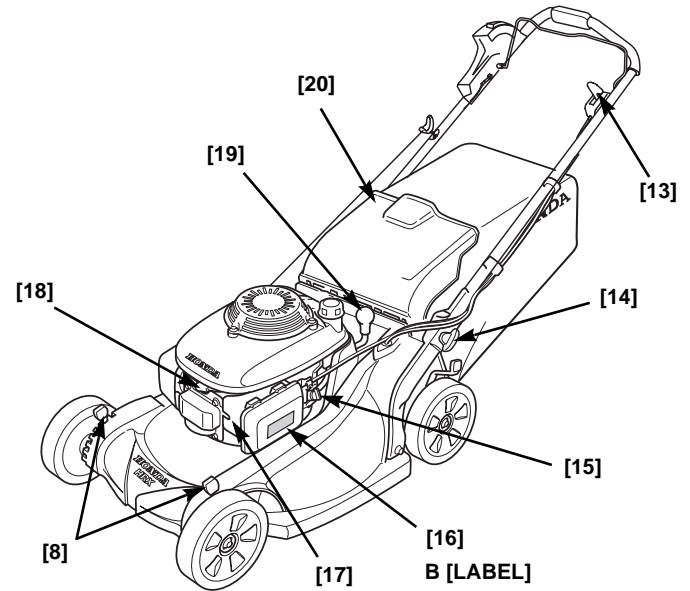
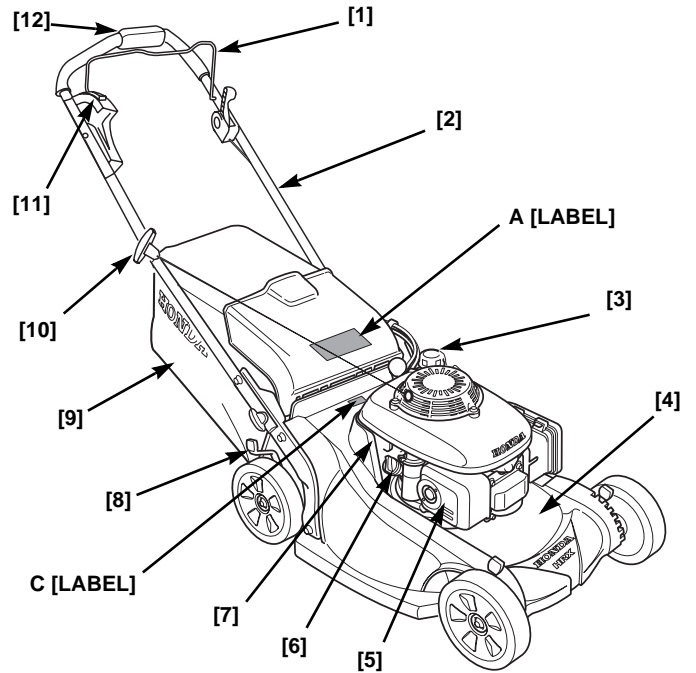

1	Blade control lever
2	Handlebar
3	Fuel tank cap
4	Mower deck
5	Muffler
6	Oil filler cap
7	Engine serial number
8	Cutting height adjustment lever (4)
9	Grass bag
10	Recoil starter

11	Roto-Stop® button
12	Smart Drive control
13	Throttle lever
14	Handlebar adjust knob (2)
15	Fuel valve
16	Air cleaner
17	Carburetor
18	Spark plug cap
19	Clip Director knob
20	Discharge guard

# SET-UP

## UNPACKING

Remove all the cardboard from around the handlebar.

## HANDLEBAR SETUP

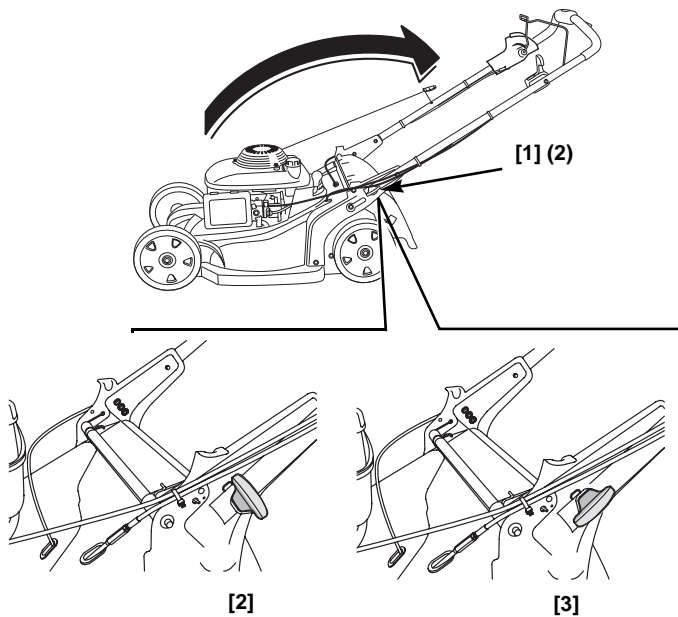

1. Turn the handlebar adjust knobs [1] 90 degrees into the unlock position [2].
2. Move the handlebar into the mowing position so that the locating pins align with either the upper, middle, or lower holes on the handlebar mounting brackets.
3. Turn the adjust knobs 90 degrees into the lock position [3] and the pins will snap into the holes and lock into position.

## GRASS BAG ASSEMBLY

Slide the grass bag frame [1] into the grass bag [2] and install the plastic clips [3] as shown.

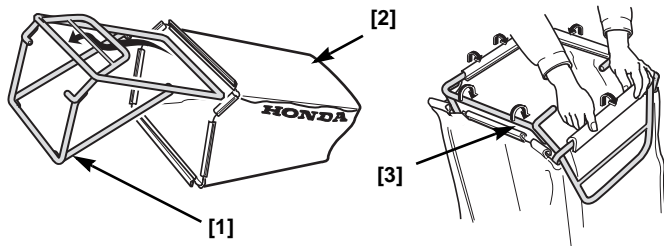

Lift the discharge guard and install the grass bag.

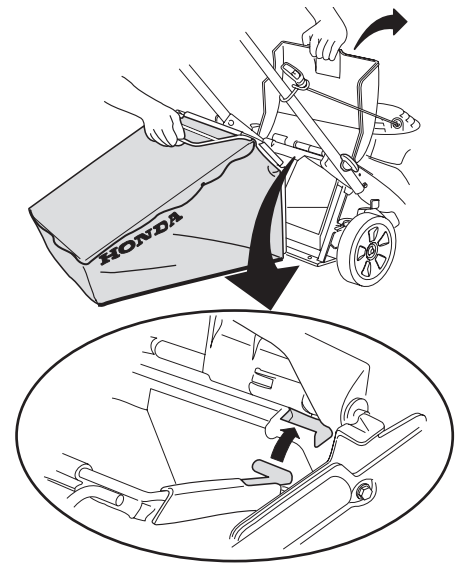

## ENGINE OIL

The mower is shipped **WITHOUT OIL** in the engine.

Add enough SAE 10W-30 API service category SJ or later oil to bring the oil level between the upper limit [2] and lower limit [3] marks on the dipstick [1] as shown.

**Do not overfill the engine with oil.** If the engine is overfilled, the excess oil may get transferred to the air cleaner housing and air filter.

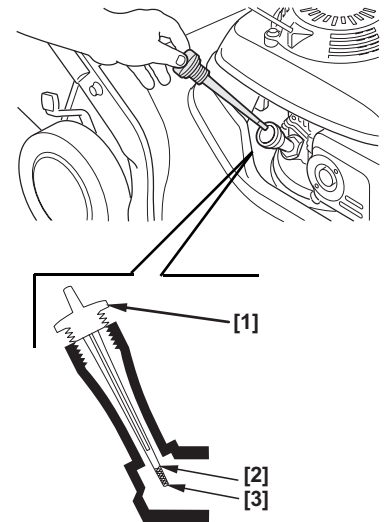

## FUEL

Refer to page 7.

## BEFORE USING YOUR LAWN MOWER

Before using the lawn mower, all mower operators must read the following chapters:

- **SAFETY INSTRUCTIONS** (page 2)
- **CONTROLS** (page 5)
- **PRE-OPERATION CHECKS** (page 6)
- **OPERATION** (page 9)
- **MAINTENANCE SCHEDULE** (page 13)

# CONTROLS

## Fuel Valve

The fuel valve [1] opens and closes the connection between the fuel tank and the carburetor.

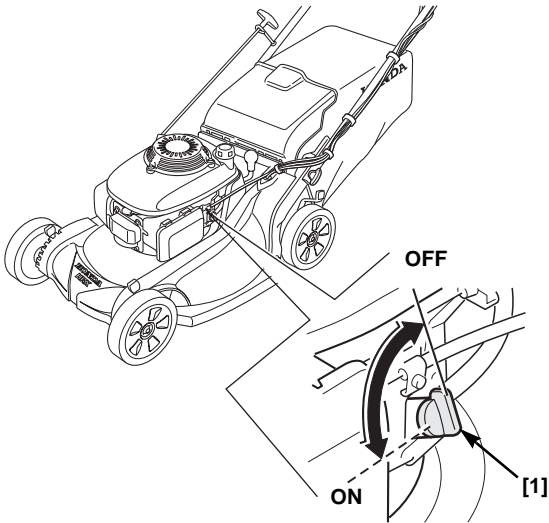

## Throttle Lever

The throttle lever [1] controls the following functions:

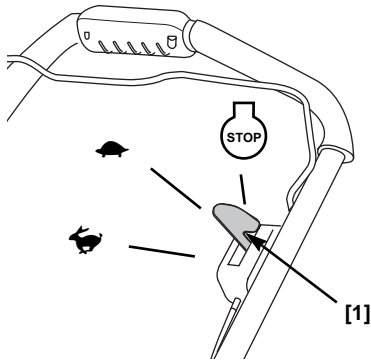

	FAST	For starting the engine and for mowing.
	SLOW	For idling the engine.
	STOP	For stopping the engine.

## Blade Control System

Blade rotation is controlled by the Roto-Stop button [1] and the blade control lever [2].

Hold the Roto-Stop button down, and then pull the blade control lever against the handlebar to engage the blade. Then release the Roto-Stop button.

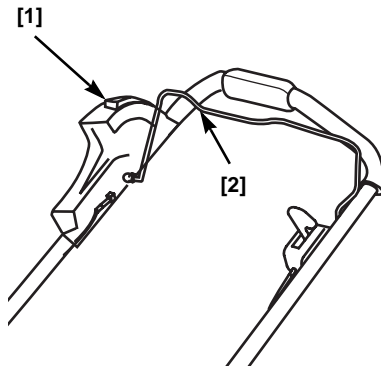

## Smart Drive Control

The Smart Drive control [1] can be adjusted up or down into any one of five positions.

1. Slide the multi-position adjuster [2] to the left to unlock the control.
2. Move the Smart Drive control up or down into the position most comfortable.
3. Release the multi-position adjuster and allow it to engage.

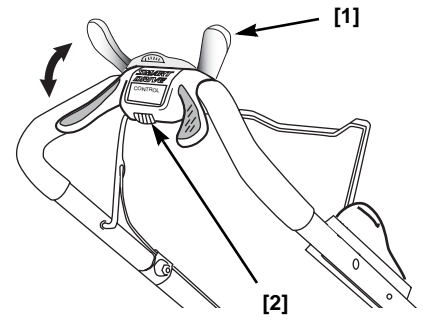

Do not attempt to adjust the position of the Smart Drive control while the mower is in motion.

## Cutting Height Adjustment Levers

There are seven adjustment settings. The cutting height figures are approximate. The actual height of cut grass will vary with lawn and soil conditions.

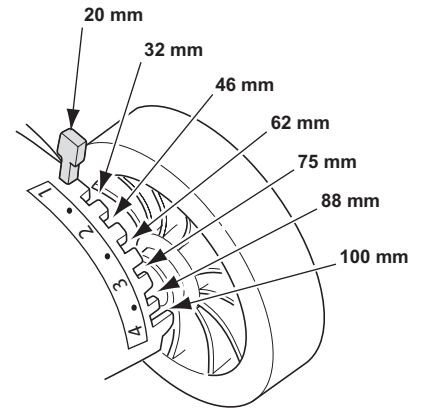

There is one adjustment lever [1] for each wheel.

[1]

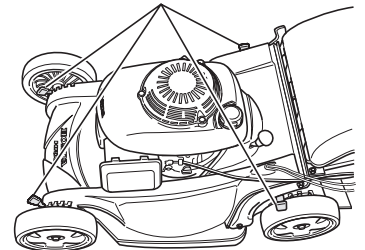

## Clip Director Knob

The Clip Director knob [1] controls bagging, mulching, and rear discharge. The knob has ten adjustment positions.

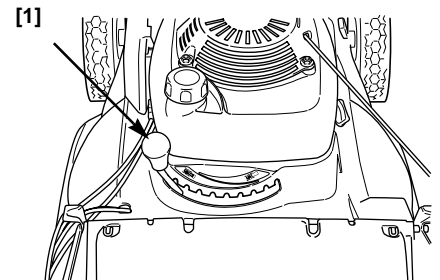

# PRE-OPERATION CHECKS

## CHECK YOUR LAWN

For your safety and for the safety of others, always inspect the area before mowing.

### Objects

Anything that can be picked up by the blades and thrown is a potential hazard to you and others. Look for things like stones, sticks, bones, and wire. Remove them from the mowing area.

### People and Pets

People and animals near the mowing area can move into your path or into a position where they could be struck by thrown objects. Clear the area of people, especially children, and pets. Their safety is your responsibility.

### Lawn

Check the length and condition of the grass, so that you will know what cutting height and mowing speed to use.

Avoid mowing wet grass. Not only will wet grass clog your mower deck and collect in clumps on the lawn, it also gives poor traction, increasing your risk of losing your footing.

## CHECK YOUR MOWER

### Blades

1. Move the throttle lever to the STOP position (page 5).
2. Move the fuel valve to the OFF position (page 5) and disconnect the spark plug cap from the spark plug (page 14).
3. Tilt the mower to the right so the fuel cap is up [1]. This will help prevent fuel leakage, motor oil seeping into the air filter, and hard starting.
4. Inspect the blades [2] for damage, cracks, and excessive wear, rust, or corrosion.

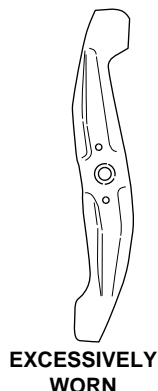
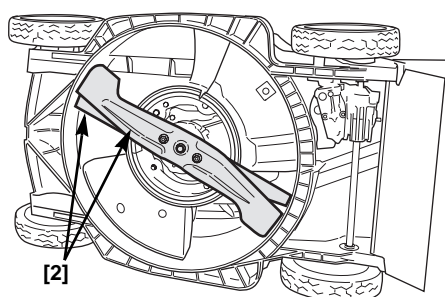
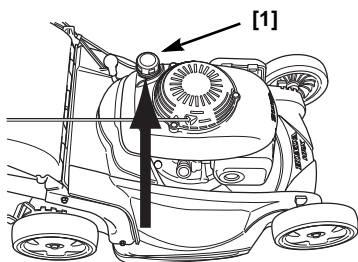

## ⚠ WARNING

A worn, cracked, or damaged blade can break, and pieces of the damaged blade can become dangerous projectiles.

Thrown objects can cause serious injury.

Inspect the blade regularly. Do not operate the mower with a worn or damaged blade.

A dull blade can be sharpened, but a blade that is worn out, bent, cracked, or otherwise damaged must be replaced. A worn or damaged blade can break, causing blade pieces to be thrown from the mower.

When a blade needs sharpening or replacement, take the lawn mower to an authorized Honda dealer. Or, if you have a torque wrench, you can remove and install the blades yourself.

Check that the blade bolts are tight (page 16).

### Engine Oil Level

Check the engine oil level with the engine stopped and the mower on a level surface.

Use 4-stroke motor oil that meets or exceeds the requirements for API service category SJ or later. Always check the API SERVICE label on the oil container to be sure it includes the letters SJ or later.

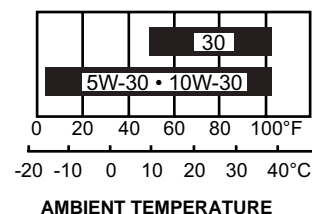

SAE 10W-30 is recommended for general use. Other viscosities shown in the chart may be used when the average temperature in your area is within the indicated range.

### NOTICE

- Running the engine with a low oil level can cause engine damage.
- Using nondetergent oil can shorten the engine's service life, and using 2-stroke oil can damage the engine.

1. Remove the oil filler cap/dipstick [1], and wipe the dipstick clean.
2. Insert the dipstick into the filler neck. Do not screw it down. Remove the dipstick and check the oil level.
3. If the oil level is near the low level mark [3], add the recommended oil to bring the level up to the high limit mark [2]. Do not overfill.
4. Install and tighten the filler cap/dipstick [1] securely.

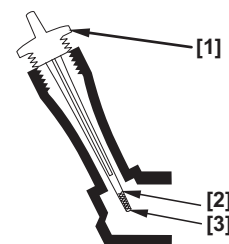
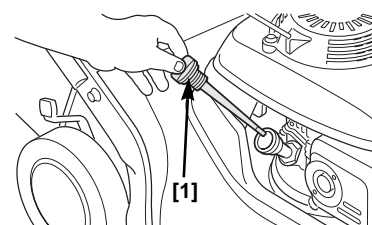

## Fuel

This engine is certified to operate on unleaded petrol with a research octane rating of 91 or higher.

Refuel in a well-ventilated area before starting the engine. If the engine has been running, allow it to cool. Never refuel the mower inside a building where petrol fumes may reach flames or sparks.

You may use regular unleaded petrol containing no more than 10% ethanol (E10) or 5% methanol by volume. In addition, methanol must contain cosolvents and corrosion inhibitors. Use of fuels with content of ethanol or methanol greater than shown above may cause starting and/or performance problems. It may also damage metal, rubber, and plastic parts of the fuel system. Engine damage or performance problems that result from using a fuel with percentages of ethanol or methanol greater than shown above are not covered by warranty.

If your equipment will be used on an infrequent or intermittent basis, please refer to the fuel section of the STORAGE chapter (page 18) for additional information regarding fuel deterioration.

### WARNING

Petrol is highly flammable and explosive.

You can be burned or seriously injured when handling fuel.

- Stop the engine and keep heat, sparks, and flame away.
- Handle fuel only outdoors.
- Wipe up spills immediately.

Never use stale or contaminated petrol or an oil/petrol mixture. Avoid getting dirt or water in the fuel tank.

### NOTICE

*Fuel can damage paint and plastic. Be careful not to spill fuel when filling your fuel tank. Damage caused by spilled fuel is not covered under warranty.*

Remove the tank cap [1] and check the fuel level. Refill the tank if the fuel level is low. Refuel carefully to avoid spilling fuel. Do not overfill; there should be no fuel in the filler neck [2].

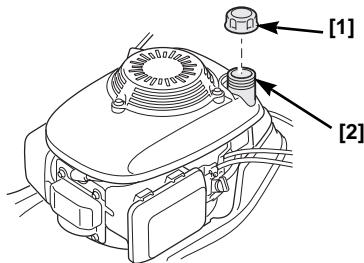

After refueling, tighten the fuel tank cap securely.

Move the mower at least 3 meters away from the fueling source and site before starting the engine.

## Air Cleaner Inspection

Remove cover [1]. Make sure the filter [2] is clean and in good condition. A dirty air filter will restrict air flow to the carburetor, reducing engine performance. Refer to page 14 for air cleaner service.

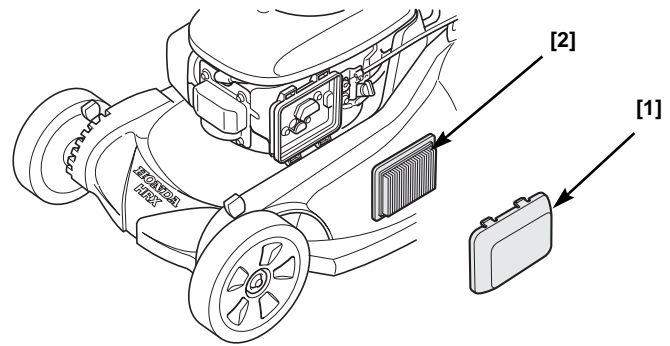

## Rear Shield

During normal use the rear shield [1] is subject to deterioration and wear. Remove the grass bag and raise the discharge guard [2] to check the rear shield for cracks or tears. If the rear shield is excessively worn, have it replaced by your authorized Honda servicing dealer.

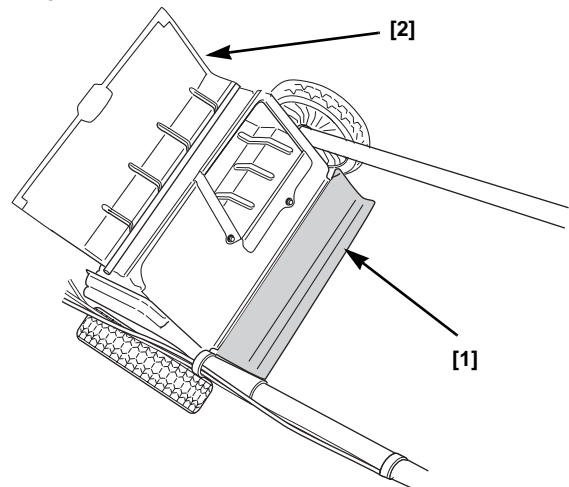

## Handlebar Height Adjustment

Adjust handlebar height to a comfortable operating position (page 4).

## Grass Bag

A lawn mower works like a vacuum cleaner; it blows air through the bag, which traps the grass clippings. Always empty the grass bag before it becomes filled to the limit of its capacity. Bagging performance will diminish after the bag becomes about 90% filled. Also, the bag is easier to empty when it is not packed full.

### Inspection

During normal use, the grass bag material is subject to deterioration and wear.

#### NOTICE

Frequently inspect the grass bag for tears, holes, and excessive wear. Check for necessary replacement. Make sure the new bag meets the original specifications.

If the grass bag needs replacement, you can remove and install a bag yourself (page 17).

### Installation

1. Raise the discharge guard [1], and use the grass bag handle [3] to hook the grass bag [2] onto the mower deck as shown.
2. Release the discharge guard to secure the grass bag.

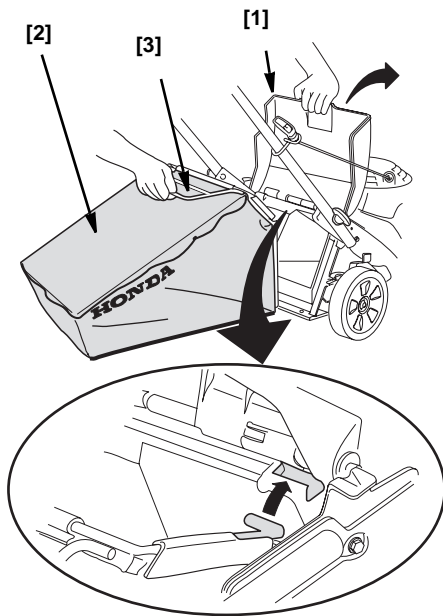

### Removal

1. Raise the discharge guard, grasp the grass bag handle, and remove the grass bag.
2. Release the discharge guard.
3. When the grass bag is clear of the discharge guard, you can lift it through the handlebar opening, or you can remove it to the rear of the mower below the handlebar.

## Cutting Height

Check the mower deck cutting height settings, and be sure that all four adjustment levers [1] are set to the same cutting height position.

To adjust cutting height, pull each adjustment lever [1] toward the wheel, and move it into another notch.

If you are not sure what cutting height to select, start with a high setting and check the appearance of the lawn after mowing a small area. Then readjust cutting height if necessary.

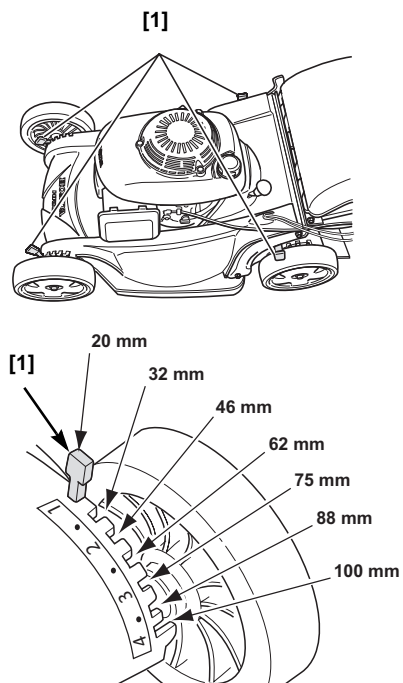

## Clip Direction

### Clip Director Knob Adjustment

Adjust the Clip Director knob [1] in any one of the ten positions to achieve the desired mowing results.

To adjust the Clip Director knob, pull the knob downward and towards the rear of the mower. The knob adjusts a sliding door [2] from the fully open BAG position to the fully closed MULCH position (see the following page).

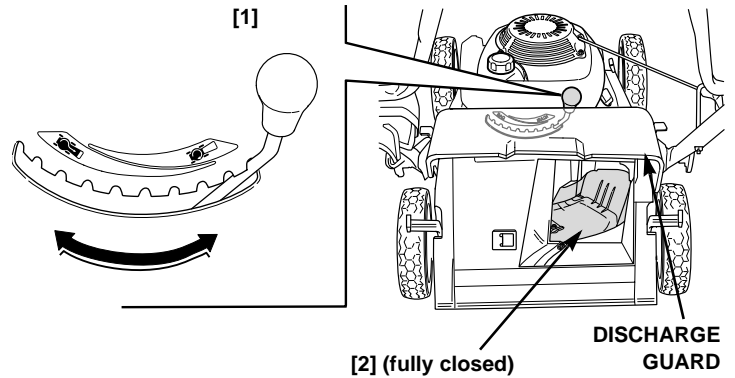

### IMPORTANT SAFETY PRECAUTION

Always turn the engine off and disconnect the spark plug cap before lifting the discharge guard to view or clean around the sliding door. This will prevent contact with the rotating blades and prevent objects from being thrown into the discharge area.

Some grass accumulation in the discharge opening is normal when the Clip Director is fully closed. To remove this grass, close the discharge guard, fully open the Clip Director, start the engine, and engage the blade control lever several times.

If a high resistance is noticed when moving the Clip Director knob from side-to-side, excessive grass may have built up on top of the sliding door.

### Sliding Door Position

The sliding door [2] can be positioned to produce different mowing results. If the preferred sliding door position is unknown, install a grass bag and begin mowing with the Clip Director knob [1] all the way to the BAG position. Check the appearance of the lawn. As the knob is moved towards the MULCH position, more grass will be recycled back into the lawn. Adjust the Clip Director knob until the desired result is achieved.

### BAGGING OR REAR DISCHARGE AND SOME MULCHING

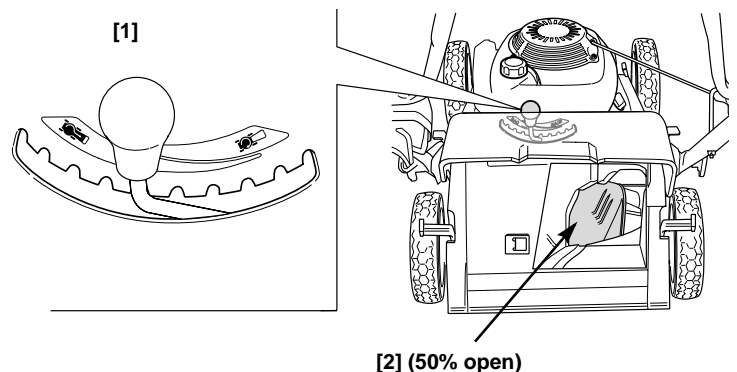



**FULL BAGGING OR REAR DISCHARGE**

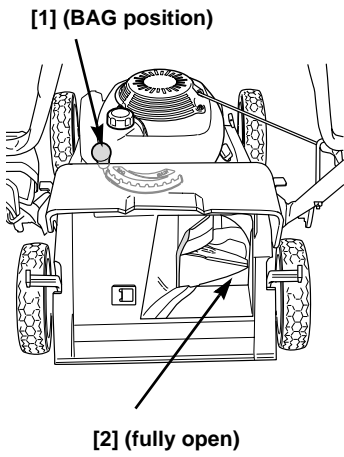

**FULL MULCHING**

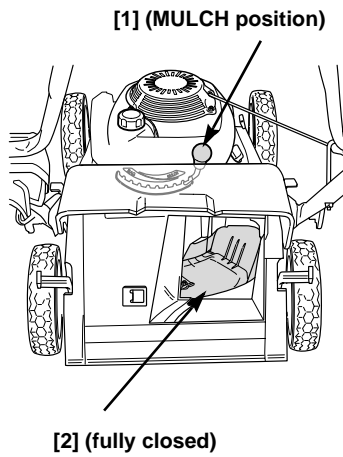

**Rear Discharge**

To discharge clippings to the rear, remove the grass bag and position the Clip Director knob [1] in the BAG range.

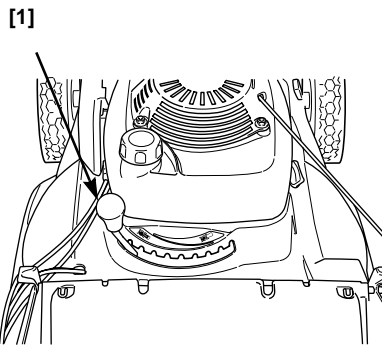

Maximum rear discharge will occur when the Clip Director knob is all the way to the left (BAG) position. As the Clip Director knob is moved toward the right (MULCH) position, less grass will be discharged through the rear discharge guard.



**Are You Ready to Mow?**

Be sure to wear protective clothing. Long pants and eye protection can lower your risk of injury from thrown objects. Wear footwear that protects your feet and won't let you slip if you mow on slopes or uneven ground.

**OPERATION**

**MOWING PRECAUTIONS**

Before operating the mower for the first time, please review *SAFETY INSTRUCTIONS* (page 2) and *PRE-OPERATION CHECKS* (page 6).

Even if you have operated other mowers, take the time to become familiar with how this mower works, and practice in a safe area until you build up your skills.

For your safety, avoid starting or operating the engine in an enclosed area such as a garage. Your mower's exhaust contains poisonous carbon monoxide gas that can collect rapidly in an enclosed area and cause illness or death.

**STARTING THE ENGINE**

1. Turn the fuel valve [1] to the ON position.

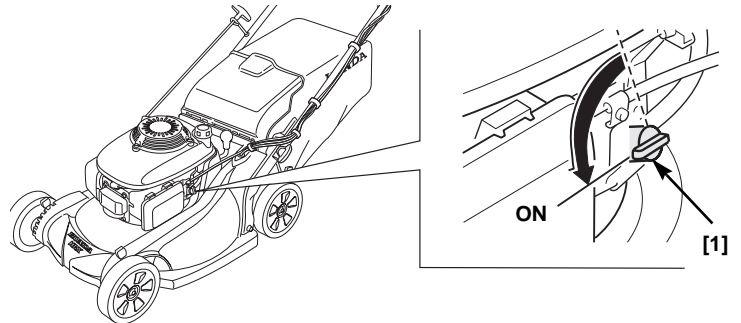

2. Move the throttle lever [1] to the FAST [2] position.

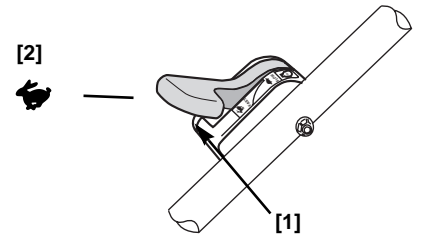

3. With the blade control lever [2] released, pull the starter grip [1] lightly until you feel resistance, then pull briskly. Return the starter grip gently.

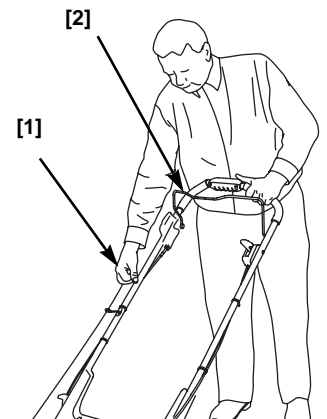

4. Put the throttle lever [1] in the FAST position [2] to mow or to the SLOW position [3] to idle.

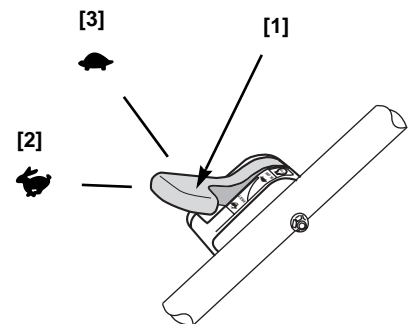

## Flooded Engine

If the engine fails to start after several pulls on the starter, the engine may be flooded.

To clear a flooded engine:

1. Place the throttle lever in the STOP position.
2. Remove and dry the spark plug. When installing the spark plug, screw it in finger tight and correctly seated. Using the correct size plug wrench, tighten it an additional 1/8 to 1/4 turn so that the washer is correctly compressed.
3. Put the throttle lever in the FAST position and repeat step 3 under *STARTING THE ENGINE* (page 9).

## High Altitude Operation

At high altitude, the standard carburetor air-fuel mixture will be too rich. Performance will decrease, and fuel consumption will increase. A very rich mixture will also foul the spark plug and cause hard starting. Operation at an altitude that differs from that at which this engine was certified, for extended periods of time, may increase emissions.

High altitude performance can be improved by specific modifications to the carburetor. If you always operate your mower at altitudes above 1,500 meters, have a Honda dealer perform this carburetor modification.

Even with carburetor modification, engine power will decrease about 3.5% for each 300 meter increase in altitude. The effect of altitude on power will be greater than this if no carburetor modification is made.

### NOTICE

*When the carburetor has been modified for high altitude operation, the air-fuel mixture will be too lean for low altitude use. Operation at altitudes below 1,500 meters with a modified carburetor may cause the engine to overheat and result in serious engine damage. For use at low altitudes, have your authorized Honda dealer return the carburetor to original factory specifications.*

## OPERATING THE CONTROLS FOR MOWING

### Throttle Lever

For best cut quality, always mow with the throttle lever [1] in the FAST position [2]. When the blades rotate at the preset fast speed, it creates a strong fan action that lifts and cuts grass more efficiently.

Do not try to increase the preset engine speed; the blade could fracture and come apart.

### Blade Control System

To start blade rotation, make sure the throttle lever is in the FAST position.

1. Push down on the Roto-Stop button [1].
2. Pull the blade control lever [2] against the handlebar and release the Roto-Stop button.

Continue to hold the blade control lever against the handlebar to maintain blade rotation.

Release the blade control lever to stop blade rotation. Always release the blade control lever before starting the engine to prevent the blades from rotating.

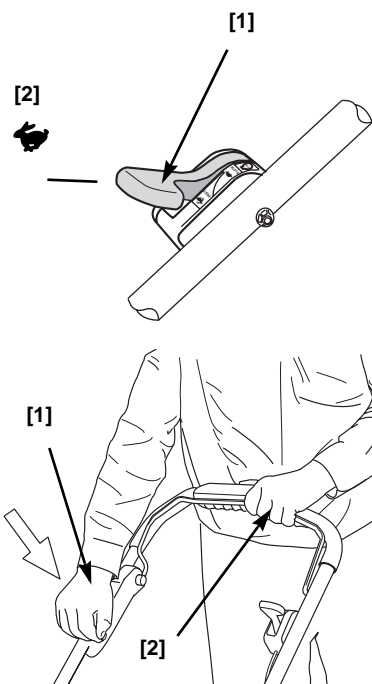

## Smart Drive Control

Control position adjustment is described on (page 5).

With the engine running and the blades rotating, slowly push the Smart Drive control [1] to propel the mower forward.

Ground speed will increase as more pressure is applied to the Smart Drive control. After maximum ground speed is obtained, applying additional force will not further increase ground speed. Apply only enough pressure to achieve the desired speed.

Ground speed control sensitivity will vary with such factors as terrain, grass height, slope, and grass bag weight. For example, achieving a very slow ground speed on smooth level terrain requires very light force to be applied to the Smart Drive control. However, additional force may be required to achieve the same ground speed on slopes, tall grass, or uneven terrain. The Smart Drive control is designed to allow you to move the control to maintain the desired ground speed under constantly changing mowing conditions.

Release the Smart Drive control to disengage (stop) the rear wheels.

## STOPPING THE ENGINE

1. Release the blade control lever [1] to stop blade rotation.
2. Move the throttle lever [2] to the STOP position to stop the engine.
3. When the mower is not in use, turn the fuel valve [3] to the OFF position.

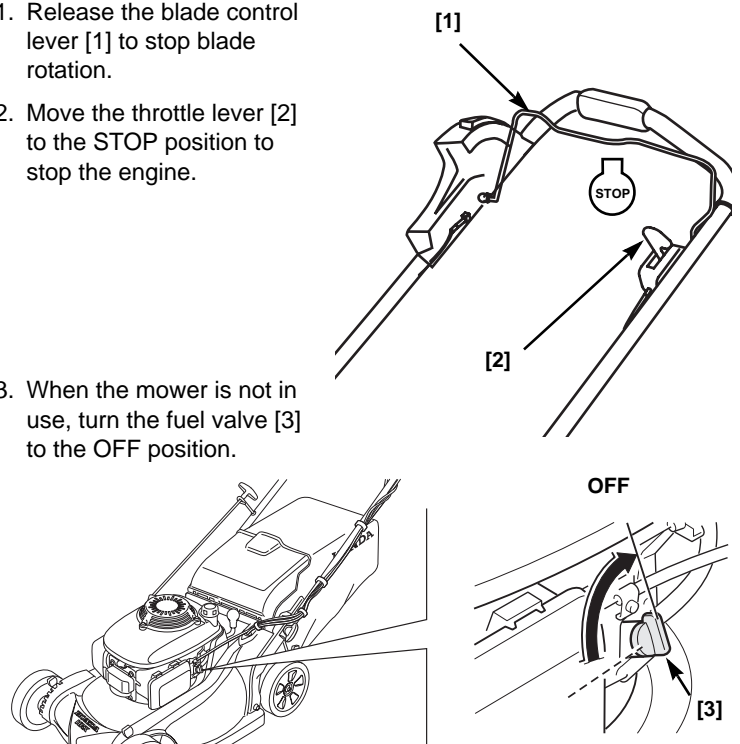

## SAFE MOWING PRACTICES

For your safety, keep all four wheels on the ground, and be careful to avoid losing your footing and your control of the mower. Keep a firm grip on the handlebar, and walk, never run, with the mower. Be very careful when mowing uneven or rough ground.

If stuck, do not kick or shove the mower with your foot. Use the handlebar to control the mower.

### WARNING

The blades are sharp and spin at high speed.

A spinning blade can cut you severely and can amputate fingers and toes.

- Wear protective footwear.
- Keep your hands and feet away from the mower deck while the engine is running.
- Stop the engine before performing any adjustment, inspection, or maintenance.

## Slopes

Mow across slopes, not up and down. Avoid steep slopes (more than 20°), and be careful when changing direction. Mowing on a slope when the grass is damp or wet could cause you to slip, fall, and lose control of the mower.

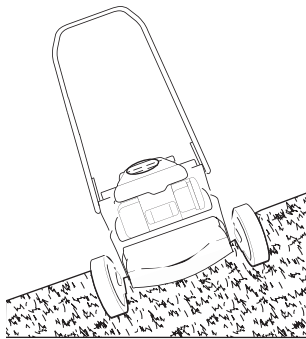

## Obstacles

Use the side of the mower to cut close to large obstacles, such as fences or walls.

Release the Smart Drive control to disengage the drive when mowing around trees and other obstacles. Push the mower around obstacles for better directional control. Be careful when mowing over obstacles embedded in the lawn, such as sprinkler heads, paving, edging, etc. Avoid anything that sticks up above the surface of the lawn.

If the blade hits something, or if the mower starts to vibrate, stop the engine immediately and check for damage. Striking objects may damage the blade, bend the crankshaft, and/or break the mower deck or other components. Vibration usually indicates serious trouble.

### WARNING

A worn, cracked, or damaged blade can break, and pieces of the damaged blade can become dangerous projectiles.

Thrown objects can cause serious injury.

Inspect the blade regularly, and do not operate the mower with a worn or damaged blade.

The warranty does not cover parts damaged by collision.

## Gravel and Loose Objects

Gravel, loose stones, and landscaping material can be picked up by the mower and thrown many feet with enough force to cause serious personal injury and/or property damage. The best way to prevent potential injury from thrown objects is to release the blade control lever to stop the blade before reaching areas with gravel, loose stones, or landscaping material.

## MOWING TIPS

### When to Mow

Most grasses should be mowed when they have grown 12 ~ 25 mm above their recommended height.

More frequent mowing is required for mulching than for bagging. For best results, you may need to mow the lawn twice a week during the growing season.

### Cutting Height

Consult a local nursery or lawn and garden center for cutting height recommendations and advice about specific types of grasses and growing conditions in your area.



LONG ENOUGH

If you look closely, you'll see that most grass has stems and leaves. If you cut off the leaves, you'll scalp the lawn. Let the grass recover between mowings. Your mower will work better, and your lawn will look better.



TOO SHORT

If your grass gets too tall, cut it once at the highest cutting height setting, and then mow again in 2 or 3 days. Don't take off more than one third of total grass height in any one mowing, or brown patches may develop.

Cutting height adjustment levers are explained in the *CONTROLS* chapter (page 5).

### Cutting Width

For an even lawn finish, overlap each mowing swath by a few centimeters. If the grass is very tall or thick, use more overlap and a narrower mowing swath.

### Blade Speed

The blades must spin very fast to cut properly. Always use the fast throttle setting, and keep the engine running at maximum rpm.

If engine speed drops, it could mean the engine is being overloaded by the blades trying to cut too much grass. Mow a narrower swath, move the mower slower, or raise the cutting height.

### Blade Sharpness

A sharp blade cuts cleanly. A dull blade tears the grass, leaving shredded ends that turn brown. When your blade doesn't cut cleanly anymore, have it sharpened or replaced.

### Dry Grass

If the ground is too dry, mowing will stir up a lot of dust. Besides being unpleasant to work in, too much dust will clog the carburetor air filter.

If dust is a problem, water your lawn the day before mowing. Mow when the grass is dry to your touch, but the soil is still moist.

### Wet Grass

Wet grass is slippery and can make you lose your footing. Also, wet grass clippings will clog the mower deck and collect in clumps on the lawn. Always wait for wet grass to dry before mowing.

## Fallen Leaves

Your mower can be used to pick up fallen leaves for disposal. If using the mower to bag large amounts of fallen leaves, and not for mowing, set the cutting height adjustment levers so the front of the mower deck is one or two settings higher than the rear.

To start, position the Clip Director knob in the #9 position (not quite full mulching). This setting will allow the leaves to be recirculated and recut until the particles are small enough to pass through the sliding door opening and into the grass bag. Depending on the size, type, and water content of the leaves, it may be necessary to open the sliding door to allow for best bagging results. Using the sliding door correctly will allow better grass bag filling, resulting in less grass bag emptying. Be sure there are no obstacles, including rocks, hidden under the leaves.

If you want to mulch fallen leaves into your lawn, don't let the leaf cover get too deep before you begin. For best results, start mulching while grass still shows through the leaf cover. Position the Clip Director knob in the MULCH position. In places where fallen leaves completely cover the grass, remove the leaves by raking, or use the grass bag so your mower can pick them up for disposal.

## Clogged Mower Deck

Before clearing a clogged mower deck, stop the engine and turn the fuel valve to the OFF position. With the spark plug cap disconnected, tilt the mower so the air cleaner side is up.

Clear a clogged deck with a stick, not your hands.

## Mowing Patterns

Your Honda mower will work most efficiently if you use the following mowing patterns as much as possible. Mower deck and equipment design, and the direction in which the blades rotate, cause these mowing patterns to give the best results.

### Mulching

Use a counterclockwise mowing pattern when the Clip Director knob is in the full MULCH position. If the lawn has an irregular shape, or many obstacles, divide it into sections where you can use counterclockwise mowing patterns.

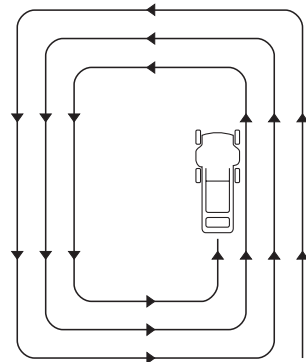

MULCHING PATTERN

### Bagging

Use a clockwise mowing pattern. This will give the best Clip Director and bagging performance, leaving the least amount of clippings on the lawn.

### Rear Discharge Mowing

Remove the grass bag and close the discharge guard. Adjust the Clip Director knob to the desired setting and begin mowing in a clockwise mowing pattern. If the lawn has an irregular shape or many obstacles, divide it into sections.

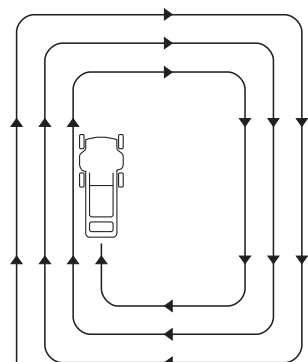

BAGGING & REAR-DISCHARGE PATTERN

# MAINTENANCE

## THE IMPORTANCE OF MAINTENANCE

Good maintenance is essential for safe, economical, and trouble-free operation. It will also help reduce air pollution.

To help you properly care for your mower, the following pages include a maintenance schedule, routine inspection procedures, and simple maintenance procedures using basic hand tools. Other service tasks that are more difficult, or require special tools, are best handled by professionals and are normally performed by a Honda technician or other qualified mechanic.

The maintenance schedule applies to normal operating conditions. If you operate your mower under unusual conditions, consult an authorized Honda dealer for recommendations applicable to your individual needs and use.

Remember that your Honda dealer knows your mower best and is fully equipped to maintain and repair it.

To ensure the best quality and reliability, use only new, Honda Genuine parts or their equivalents for repair and replacement.

## ⚠ WARNING

Improper maintenance, or failure to correct a problem before operation, can cause a malfunction in which you can be seriously hurt or killed.

Always follow the inspection and maintenance recommendations and schedules in this owner's manual.

## MAINTENANCE SAFETY

Some of the most important safety precautions follow. However, we cannot warn you of every conceivable hazard that can arise in performing maintenance. Only you can decide whether or not you should perform a given task.

## ⚠ WARNING

Failure to properly follow maintenance instructions and precautions can cause you to be seriously hurt or killed.

Always follow the procedures and precautions in this owner's manual.

## Safety Precautions

- Make sure the engine is off before you begin any maintenance or repairs. This will eliminate several potential hazards:
  - **Carbon monoxide poisoning from engine exhaust.**  
Be sure there is adequate ventilation whenever you operate the engine.
  - **Burns from hot parts.**  
Let the engine and exhaust system cool before touching.
  - **Injury from moving parts.**  
Do not run the engine unless instructed to do so.
- Read the instructions before you begin, and make sure you have the tools and skills required.
- To reduce the possibility of fire or explosion, be careful when working around petrol. Use only a nonflammable solvent, not petrol, to clean parts. Keep cigarettes, sparks, and flames away from all fuel-related parts.

## MAINTENANCE SCHEDULE

Interval	Item
Before each use	Inspect the blades (page 6) Check the blade bolt torque (page 16) Check the rear shield (page 7) Check the grass bag (page 17) Check the engine oil level (page 6) Check the air cleaner (page 7)
First month or 5 hours	Change the engine oil (page 13)
First 20 hours	Clean the air filter element (page 14) <sup>1</sup> Adjust the throttle cable (page 15) Adjust the Roto-Stop cable <sup>2</sup> Adjust the Smart Drive cable (page 15)
Every 50 hours	Change the engine oil (page 13) <sup>1</sup> Clean the air filter element (page 14) <sup>1</sup> Adjust the Smart Drive cable (page 15)
Every 100 hours	Change the engine oil (page 13) <sup>1</sup> Clean the air filter element (page 14) <sup>1</sup> Check-adjust the spark plug (page 14) Clean the spark arrester <sup>3</sup> (page 15) Adjust the throttle cable (page 15) Adjust the Roto-Stop cable <sup>2</sup> Adjust the Smart Drive cable (page 15) Grease the pinion gears <sup>2</sup>
Every 150 hours	Change the engine oil (page 13) <sup>1</sup> Replace the air cleaner filter (page 14) Replace the spark plug (page 14) Adjust the idle speed (page 15) Adjust the Smart Drive cable (page 15) Adjust the valve clearance <sup>2</sup> Clean the fuel tank and strainer <sup>2</sup>
Every 2 years	Check the fuel line and replace if necessary <sup>2</sup>
After every 250 hours	Clean the combustion chamber <sup>2</sup>

1. Service more frequently when used in dusty areas.
2. These items should be serviced by an authorized Honda servicing dealer, unless you have the proper tools and are mechanically proficient. Refer to the Honda shop manual for service procedures.
3. In Europe and other countries where machinery directive 2006/42/EC is enforced, this cleaning should be done by your servicing dealer.

Failure to follow this maintenance schedule could result in non-warrantable failures.

## ENGINE MAINTENANCE

### Engine Oil Change

Drain the oil while the engine is warm. Warm oil drains quickly and completely.

1. Put the throttle lever in the STOP position and turn the fuel valve OFF. This will reduce the possibility of fuel leakage (page 5).
2. Wipe the oil filler area clean, and then remove the oil filler cap/dipstick.
3. Place a suitable container next to the mower to catch the used oil, and then tilt the mower on its right side. The used oil will drain through the filler neck. Allow the oil to drain completely.

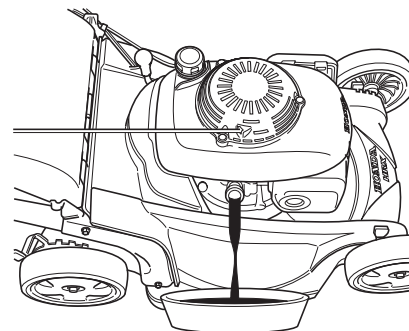

Please dispose of used motor oil and the containers in a manner that is compatible with the environment. We suggest you take it in a sealed container to your local recycling center or service station for reclamation. Do not throw it in the trash, pour it on the ground or pour it down a drain.

4. Fill with the recommended oil (page 6). Do not overfill. Measure the oil level as shown.
5. After changing the engine oil and before starting the engine, check the oil level with the mower on a level surface:
  - a. Remove the filler cap/dipstick [1].
  - b. Wipe the dipstick clean.
  - c. Insert and remove the dipstick without screwing it into the filler neck. Check the oil level shown on the dipstick.
  - d. If the oil level is below the low level mark [3], add oil to reach the high limit mark [2] on the dipstick. Do not overfill. If the engine is overfilled, the excess oil may get transferred to the air cleaner housing and air cleaner filter.

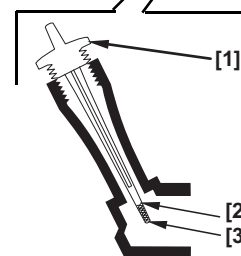
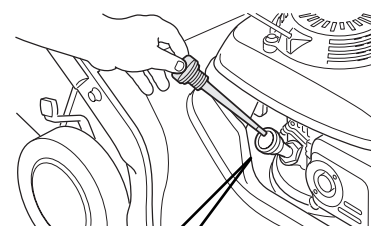
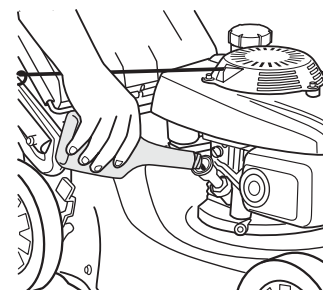

#### NOTICE

*Running the engine with a low oil level can cause engine damage.*

- e. Screw in the filler cap/dipstick securely.

## Air Cleaner Service

A dirty air filter will restrict air flow to the carburetor, reducing engine performance. If you operate the mower in very dusty areas, clean the air filter more often than specified in the *MAINTENANCE SCHEDULE* (page 13).

### NOTICE

*Operating the engine without an air filter, or with a damaged filter, will allow dirt to enter the engine, causing rapid engine wear. This type of damage is not covered by the warranty.*

1. Press down on the air cleaner cover [1] tabs, and then remove the cover.
2. Remove the filter [2] from the air cleaner housing [3].
3. Inspect the filter; replace if damaged.
4. Clean the filter by tapping the filter several times on a hard surface to remove dirt, or blow compressed air (not exceeding 207 kPa) through the filter from the inside. Never try to brush off dirt; brushing will force dirt into the fibers.
5. Wipe dirt from the inside of the air cleaner housing and cover, using a moist rag. Be careful to prevent dirt from entering the air duct that leads to the carburetor.
6. Reinstall the filter and cover.

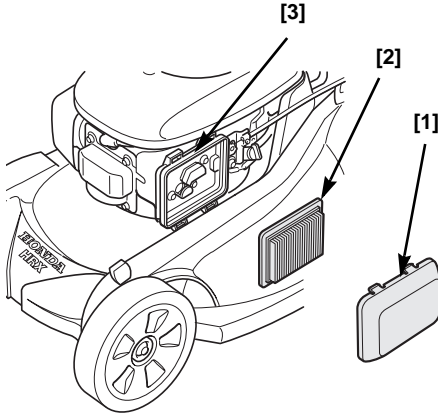

## Spark Plug Service

Recommended spark plug: NGK - BPR5ES

### NOTICE

*Incorrect spark plugs can cause engine damage.*

For good performance, the spark plug [1] must be properly gapped and free of deposits.

1. Disconnect the spark plug cap [2], and remove any dirt from around the spark plug area.

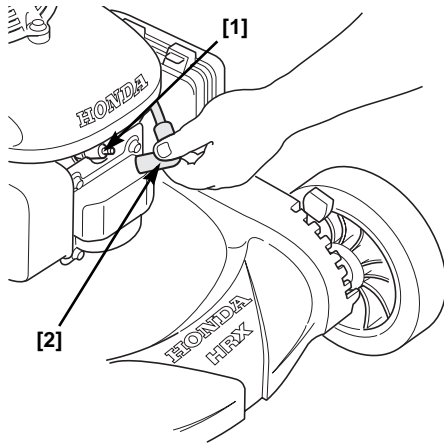

2. Remove the spark plug with a spark plug wrench [3].

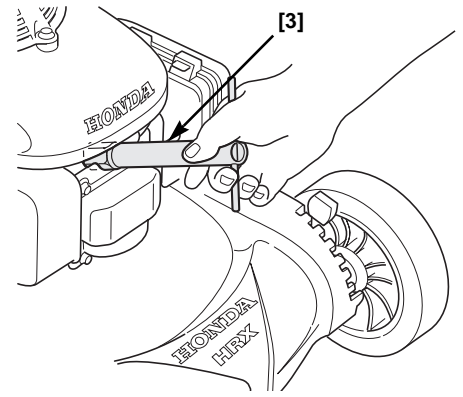

3. Inspect the spark plug. Replace it if the electrodes are worn or if the insulator is cracked or chipped.
  4. Measure the spark plug electrode gap with a suitable gauge. The gap should be 0.7 ~ 0.8 mm. Correct the gap, if necessary, by carefully bending the side electrode.
  5. Install the spark plug carefully, by hand, to avoid cross-threading.
  6. After the spark plug seats, tighten with a spark plug wrench to compress the washer.
- If reinstalling the old spark plug, tighten 1/8 to 1/4 turn after the spark plug seats.
- If installing a new spark plug, tighten 1/2 turn after the spark plug seats to compress the washer [4].

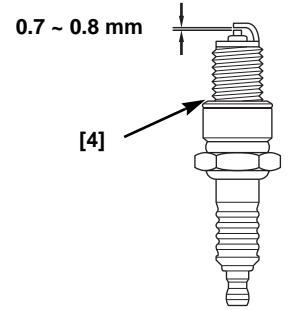

### NOTICE

*A loose spark plug can overheat and damage the engine. Overtightening the spark plug can damage the threads in the cylinder head.*

7. Install the spark plug cap on the spark plug.

## Spark Arrester Service

In Europe and other countries where machinery directive 2006/42/EC is enforced, this cleaning should be done by your servicing dealer.

The spark arrester must be serviced every 100 hours to keep it functioning as designed.

1. Allow the engine to cool, and then remove the three bolts [1] from the muffler shield [2] using a 10 mm socket wrench.
2. Remove the muffler shield [2].
3. Remove the screw [4].
4. Remove the spark arrester [3] from the muffler [5].
5. Check for carbon deposits on the spark arrester and the exhaust port. Brush carbon deposits away. Be careful to avoid damaging the spark arrester screen.
6. Install the spark arrester in the muffler.

Install the muffler components on the engine, and tighten the three bolts securely.

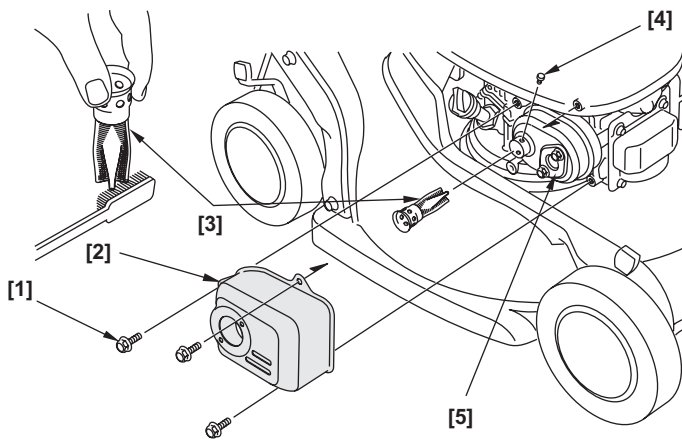

## Carburetor Adjustments

1. Start the engine outdoors, and allow it to warm up to normal operating temperature.
2. Set the throttle lever in the SLOW position.
3. With the blade control disengaged, turn the throttle stop screw [2] to obtain the standard idle speed.

**Standard idle speed:**  
**1,700 ± 150 rpm**

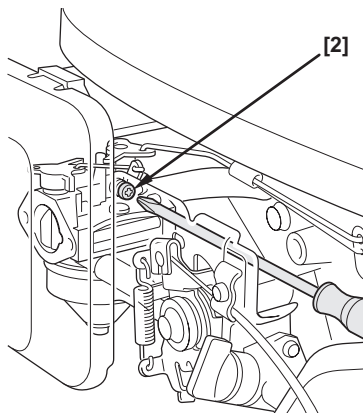

## Smart Drive Cable

Perform this procedure with the wheels on a level surface.

1. Loosen the Smart Drive clutch cable lock nut [1].
2. Start the engine.
3. Without engaging the Smart Drive grip, turn the clutch cable adjuster [2] in the MOVE direction until the lawn mower just begins to move forward.
4. Turn the clutch cable adjuster 1 ~ 2 turns in the STOP direction.
5. Tighten the clutch cable lock nut.
6. Check the operation of the Smart Drive system.

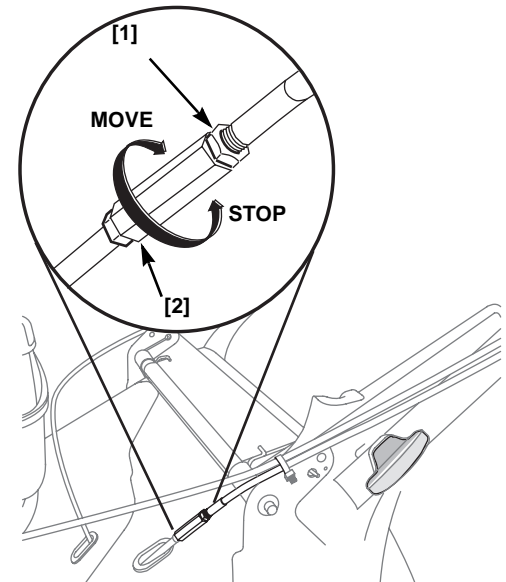

## Throttle Cable Adjustment

1. Move the throttle lever [1] to the FAST position [2].
2. Remove the air cleaner cover.

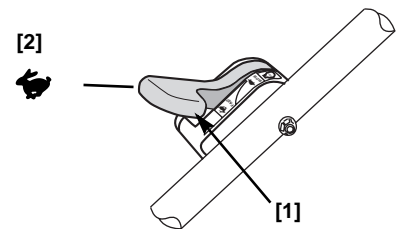

3. Check that the control lever [3] just touches the stopper screw [4].
4. If adjustment is required, loosen the throttle clamp screw [5] and move the throttle cable until the control lever just touches the stopper screw. Tighten the clamp screw.

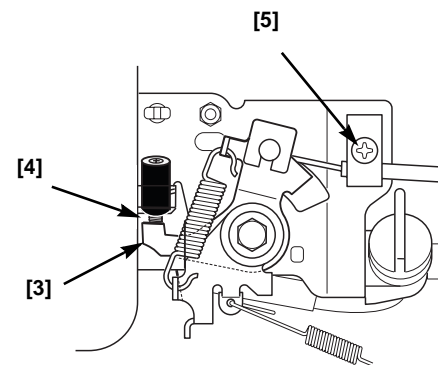

## BLADE REMOVAL AND INSTALLATION

If you remove the blades for sharpening or replacement, you will need a torque wrench for installation. Wear heavy gloves to protect your hands.

**BLADE SHARPENING:** To avoid weakening the blades, or causing imbalance or poor cutting, the blades should be sharpened by trained staff at an authorized Honda dealer.

**BLADE REPLACEMENT:** Use Honda Genuine replacement blades or their equivalent.

### Blade Removal

1. Put the throttle lever in the STOP position.
2. Turn the fuel valve OFF and disconnect the spark plug cap from the spark plug.
3. Tilt the mower to the right so the fuel cap is up. This will help to prevent fuel leakage, motor oil seeping into the air filter, and hard starting.
4. Use a 14 mm (6 point) socket wrench and remove the two blade bolts [1] and special washers [2] from the blade control assembly [5]. Use a wooden block to prevent the blades from turning when removing the bolts.

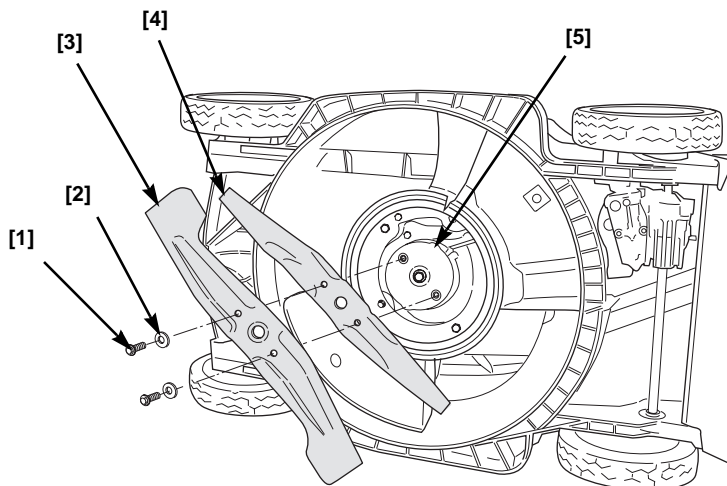

5. Remove the upper [4] and lower blades [3].

### Blade Installation

## ⚠ WARNING

Operating this mower with only one blade will result in an improperly seated blade that can be thrown from the mower and seriously hurt or kill someone.

Always install both blades as a set.

1. Clean dirt and grass from around the blade mounting area.
2. Install both blades [3] and [4] using the two blade bolts [1] and special washers [2] as shown.

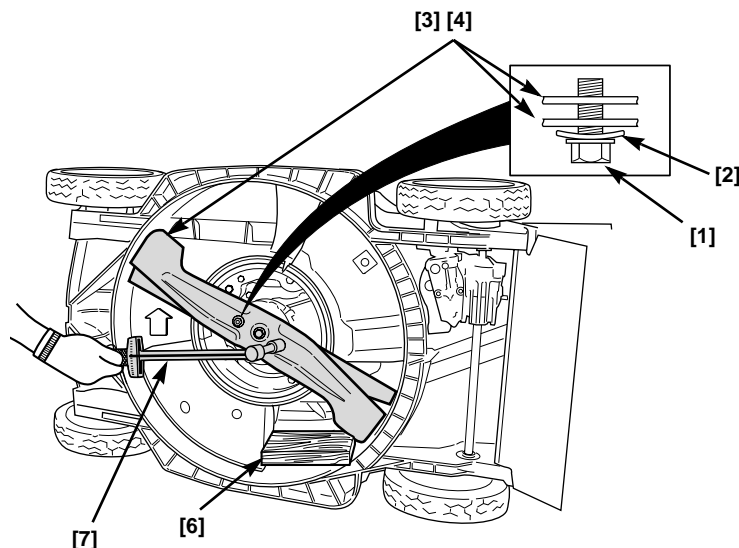

Be sure to install the special washers with the concave side toward the blades and the convex side toward the head of the bolt.

The blade bolts are specially designed for this application and must not be replaced with other bolts.

3. Tighten the blade bolts with a torque wrench [7]. Use a wooden block [6] to prevent the blades from turning.

### Blade bolt torque: 49 ~ 59 N·m

If you do not have a torque wrench, have an authorized Honda dealer tighten the blade bolts before you use the mower. If the blade bolts are overtightened, they could break. If the blade bolts are not tightened enough, they could loosen or come out. In either case, it would be possible for the blades to fly off while you are operating the mower.



## GRASS BAG CLEANING AND REPLACEMENT

### Grass Bag Cleaning

Wash the bag with a garden hose, and allow it to dry completely before use; a wet bag will clog quickly.

### Grass Bag Replacement

Replace a worn or damaged bag with a Honda replacement bag or its equivalent.

#### Bag Removal

1. Unclip the plastic edges [1] of the bag [2] from the frame [3].
2. Remove the bag from the frame.

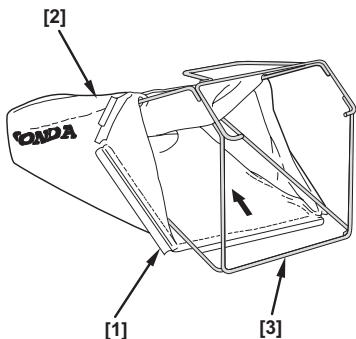

#### Bag Installation

1. Insert the bag frame [3] into the bag [2], as shown above.
2. Clip the plastic edges [1] of the bag onto the frame.

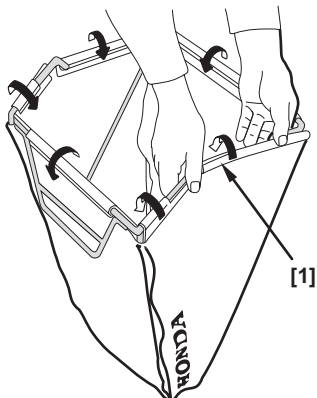

## TRANSPORTING

### Before Loading

If the engine has been running, allow it to cool for at least 15 minutes before loading the mower on the transport vehicle. A hot engine and exhaust system can burn you and can ignite some materials.

Turn the fuel valve to the OFF position. This will prevent carburetor flooding and reduce the possibility of fuel leakage.

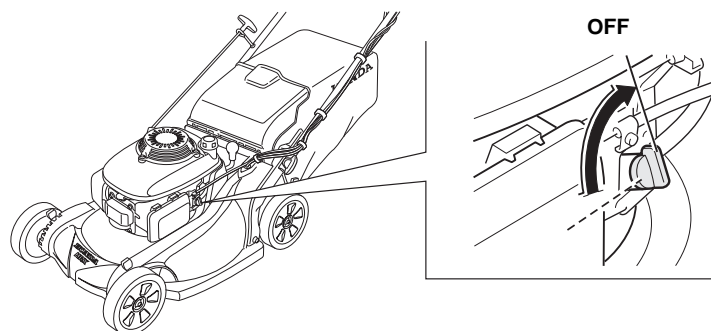

### Handlebar Folding

1. Remove the grass bag, if so equipped. You can place it on top of the engine, with the bag opening to the front.
2. Unlock the handlebar adjust knobs [1], and then swing the handlebar [2] forward.

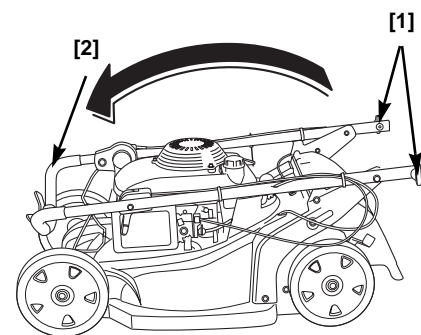

When folding the handlebar, be careful to avoid kinking or pinching the control cables.

### Loading and Unloading

Position the mower so all four wheels are on the bed of the transport vehicle. Tie the mower down with rope or straps, and block the wheels. Keep the tie-down rope or straps away from the controls, adjustment levers, cables, and the carburetor.

#### NOTICE

*To prevent losing control of or damaging the mower, do not use the drive system when going up or down a loading ramp.*

*To prevent damaging the drive system, do not engage the clutch when the mower is rolling backwards.*

1. Turn the fuel valve to the OFF position.
2. Use a suitable loading ramp. Adjust the loading ramp so that it is inclined at an angle of less than 15°. If a loading ramp is not available, two people should lift the mower on and off the transport vehicle while keeping the mower level.

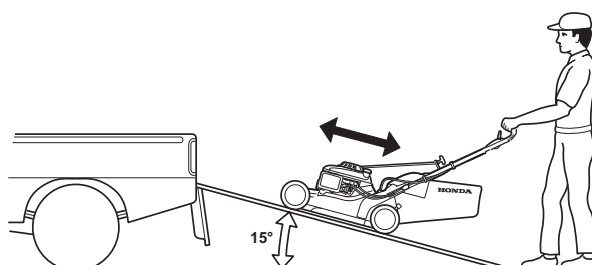

# STORAGE

Proper storage is essential for keeping your lawn mower troublefree and looking good. The following steps will help protect the mower from rust and corrosion, and make the engine easier to start when you use the lawn mower again.

## Cleaning

### Engine

Wash the engine by hand, and be careful to prevent water from entering the air cleaner.

#### NOTICE

*Using a garden hose or pressure washing equipment can force water into the air cleaner. Water in the air cleaner will soak the paper filter and can enter the carburetor or engine cylinder, causing damage. Water contacting a hot engine can cause damage. If the engine has been running, allow it to cool for at least half an hour before washing.*

### Mower Deck

Before washing the underside of the mower deck, be sure the fuel valve is in the OFF position. Disconnect the spark plug cap. Rest the mower on its right side so the fuel filler cap is up. This will help prevent fuel leakage and hard starting due to carburetor flooding. Wear heavy gloves to protect your hands from the blades.

Wash the lawn mower, including the underside of the mower deck.

If using a garden hose or pressure washing equipment to clean the mower deck, be careful to avoid getting water into controls and cables, or anywhere near the engine air cleaner or muffler opening.

### Grass Bag

Remove the bag from the mower, and wash it with a garden hose or pressure washing equipment. Allow the bag to dry completely before storage.

## Drying

1. After washing the lawn mower, wipe dry all accessible surfaces.
2. With the mower in an upright position, move the Clip Director knob to the BAG position, start the engine outdoors, and let it run until it reaches normal operating temperature to evaporate any water remaining on the engine.
3. Stop the engine and allow it to cool.
4. After the lawn mower is clean and dry, touch up any damaged paint and coat other areas that may rust with a light film of oil.

## Fuel

#### NOTICE

*Depending on the region where you operate your equipment, fuel formulations may deteriorate and oxidize rapidly. Fuel deterioration and oxidation can occur in as little as 30 days and may cause damage to the carburetor and/or fuel system. Please check with your servicing dealer for local storage recommendations.*

Petrol will oxidize and deteriorate in storage. Old petrol will cause hard starting, and it leaves gum deposits that clog the fuel system. If the petrol in your mower deteriorates during storage, you may need to have the carburetor and other fuel system components serviced or replaced.

The length of time that petrol can be left in your fuel tank and carburetor without causing functional problems will vary with such factors as petrol blend, your storage temperatures, and whether the fuel tank is partially or completely filled. The air in a partially filled fuel tank promotes fuel deterioration. Very warm storage temperatures accelerate fuel deterioration. Fuel deterioration problems may occur within a few months, or even less if the petrol was not fresh when you filled the fuel tank.

To prevent fuel related problems:

1. Add petrol stabilizer following the manufacturer's instructions.

When adding a petrol stabilizer, fill the fuel tank with fresh petrol. If only partially filled, air in the tank will promote fuel deterioration during storage.

2. After adding a petrol stabilizer, run the engine outdoors for 10 minutes to be sure that treated petrol has replaced the untreated petrol in the fuel system.

3. Turn the fuel valve [1] to the OFF position.

4. Continue to run the engine until it stops from the lack of fuel in the carburetor fuel bowl. Running time should be less than 3 minutes.

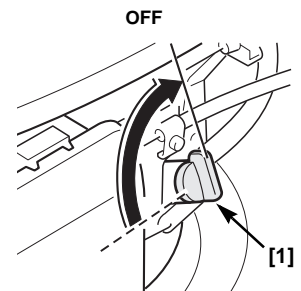

Fuel system damage or engine performance problems resulting from neglected storage preparation are not covered under warranty.

## Engine Oil

Change the engine oil (page 13).

## Engine Cylinder

If the mower is to be stored for more than 3 months, remove the spark plug (page 14). Pour 5 ~ 10 cc of clean engine oil into the cylinder [1]. Pull the starter rope several times to distribute the oil in the cylinder. Reinstall the spark plug.

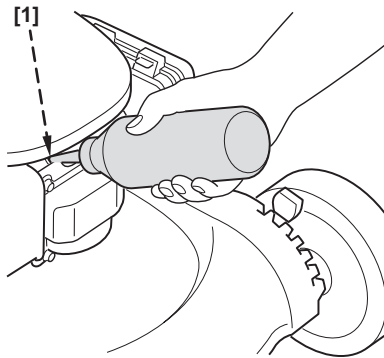

Pull the starter rope slowly until resistance is felt, then return the starter grip gently. This will close the valves so moisture cannot enter the engine cylinder.

## PLACING IN STORAGE

Since your mower will be stored with petrol in the fuel tank and carburetor, it is important to reduce the hazard of petrol vapor ignition. Select a well-ventilated storage area away from any appliance that operates with a flame, such as a furnace, water heater, or clothes dryer. Also avoid any area with a spark-producing electric motor, or where power tools are operated.

If possible, avoid storage areas with high humidity, because that promotes rust and corrosion.

Place the mower with its wheels on a level surface. Tilting can cause fuel or oil leakage.

The handlebar can be folded for compact storage (page 17).

With the engine and exhaust system cool, cover the mower to keep out dust. A hot engine and exhaust system can ignite or melt some materials. Do not use sheet plastic as a dust cover. A nonporous cover will trap moisture around the mower, promoting rust and corrosion.

## REMOVING FROM STORAGE

Check your mower as described in *PRE-OPERATION CHECKS* (page 6).

If the cylinder was coated with oil during storage preparation, the engine will smoke briefly at startup. This is normal.

# TROUBLESHOOTING

## ENGINE WILL NOT START

Possible Cause	Correction
Fuel valve OFF	Turn the fuel valve ON (page 5).
Throttle lever in the wrong position	Move the throttle lever to the FAST position (page 5).
Out of fuel	Refuel (page 7).
Bad fuel; mower stored without treating the petrol, or refueled with bad petrol	Refuel with fresh petrol (page 7).
Spark plug faulty, fouled, or improperly gapped	Gap or replace the spark plug (page 14).
Spark plug wet with fuel (flooded engine)	Dry and reinstall the spark plug.
Fuel filter clogged, carburetor malfunction, ignition malfunction, valves stuck, etc.	Take the mower to an authorized Honda servicing dealer or refer to the shop manual for repair.

## LOSS OF POWER

Possible Cause	Correction
Throttle not set to FAST	Move the throttle to FAST (page 5).
Grass is too tall to cut	Raise the cutting height (page 8), cut a narrower swath, use a slower ground speed (page 5), or cut more frequently.
Mower deck is clogged	Clean out the mower deck (page 12).
Air cleaner is clogged	Clean or replace the air cleaner (page 14).
Bad fuel; mower stored without treating the petrol, or refueled with bad petrol	Refuel with fresh petrol (page 7).
Fuel filter clogged, carburetor malfunction, ignition malfunction, valves stuck, etc.	Take the mower to an authorized Honda servicing dealer or refer to the shop manual for repair.

## VIBRATION

Possible Cause	Correction
Grass and debris lodged under the mower deck	Clean out the mower deck (page 12).
Blades loose, bent, damaged, or unbalanced by improper sharpening	Tighten loose blade bolts (page 16). If blades are found to be bent or damaged, take the lawn mower to an authorized Honda servicing dealer for inspection.
Mechanical damage, such as a bent crankshaft	Take the mower to an authorized Honda servicing dealer or refer to the shop manual for repair.

## MOWING AND BAGGING PROBLEMS

Possible Cause	Correction
Engine speed is too slow to cut well	Move the throttle lever to the FAST position (page 5).
Mower is moving too fast for lawn conditions	Move the Smart Drive to a slow speed (page 10) or push slower.
Cutting height adjustment levers set at different positions	Set all levers at the same cutting height position (page 8).
Grass bag overfilled or clogged	Empty the grass bag. Wash the grass bag if it is clogged with dirt (page 17).
Mower deck is clogged	Clean out the mower deck (page 12).
Blades dull, worn, or damaged	Sharpen or replace the blades if necessary (page 16).
Wrong blades installed	Install correct blades (page 16).

# SPECIFICATIONS

<b>MODEL</b>	HRX537C2
<b>TYPE</b>	VYEA
<b>DESCRIPTION CODE</b>	MAGA

## GENERAL

Length	1,621 mm
Handlebar height (Middle position)	976 mm
Dry weight	43.8 kg
Width	585 mm
Cut width	530 mm
Cut height adjustments	20 mm, 32 mm, 46 mm, 62 mm, 75 mm, 88 mm, 100 mm
Grass bag capacity	88 ℓ
Sound pressure level at operator's ears (According to 2006/42/EC directive)	86 dB(A)
Uncertainty	1 dB(A)
Sound power level measured (According to 2000/14/EC directive)	97 dB(A)
Uncertainty	1 dB(A)
Sound power level guaranteed (According to 2000/14/EC directive)	98 dB(A)
Vibration transmitted (According to 2006/42/EC directive)	4.5 m/s <sup>2</sup>
Uncertainty	2.3 m/s <sup>2</sup>

## ENGINE

Model	GCV190
Type	4-stroke, single cylinder, vertical shaft, OHC
Displacement	187 cc
Bore and stroke	69 x 50 mm
Cooling	Forced air
Lubrication	Splash and spray
Compression ratio	8.5:1
Maximum speed	2,850 <sup>+0</sup> <sub>-100</sub> rpm
Idle speed	1,700 ± 150 rpm
Ignition system	Transistorized magneto
Spark plug	NGK: BPR5ES
Spark plug gap	0.7 ~ 0.8 mm
Air cleaner	Dry element type
Recommended fuel	Unleaded petrol with a research octane rating of 91 or higher
Fuel tank capacity	0.91 ℓ
Recommended oil	SAE 10W-30, API SJ or later
Engine oil capacity	0.55 ℓ * Refill amount: 0.35 ~ 0.40 ℓ

\* Actual amount will vary due to residual oil in the engine. Always use the dipstick to confirm the actual level (see page 6).

## DRIVE

Type	Variable speed transmission, thumb or hand operation (twist grip)
Engine to transmission	V-belt
Main clutch	Slipping friction cone type
Mower speed (engine @ 2,850 rpm)	0 ~ 1.6 m/s

# Honda Warranty Conditions

Thank you for purchasing your Honda lawn mower.

Honda warrants your new mower to be free of defects in materials or workmanship for a period of 2 years from the date of purchase (3 months for commercial use). This warranty is in addition to your statutory rights.

However, in the unlikely event that you encounter a problem with your mower, please contact your original retailer. Should your machine require repair under warranty, you will need to take it to an authorised Honda dealer with either the warranty card or your proof of purchase.

## **There are, of course, some Terms and Conditions that apply to the Honda warranty. Listed here are items that are not covered:**

1. Any damage resulting from neglect of the periodic maintenance specified by Honda.
2. Any damage resulting from repair or maintenance performed by non-authorized Honda service points.
3. Any damage resulting from operating methods other than those indicated in the owner's manual of the product.
4. Any damage resulting from the use of non-genuine Honda parts, other than recommended lubricants and fluids, and accessories other than those approved by Honda.
5. Any damage or deterioration due to natural wear and tear (natural fading of painted or plated surfaces, sheet peeling and other natural deterioration).
6. Consumable parts: Honda does not warrant parts deterioration due to natural wear and tear. The parts listed below are not covered by warranty (unless they are needed as a part of another warranty repair):
  - Spark plug, fuel filter, air cleaner element, brake pad, clutch disc, tyre, wheel, wheel bearing, recoil starter rope, cable, belt, cutter blade.
  - Lubricant: oil and grease.
7. Cleaning, adjustment, and normal periodic maintenance work (carburetor cleaning, engine oil draining, blade sharpening, belt and cables adjustment).
8. Expenses incidental to the warranty claim, including:
  - Compensation for loss of time, commercial loss or rental costs for a substitute product.
  - Costs incurred for transportation to and from the dealership.
9. Any damage resulting from exposure of the product to soot and smoke, chemical agents, bird droppings, sea water, sea breeze, salt or other environmental phenomena.

## Conditions D'application De La Garantie Honda

Nous vous remercions d'avoir acheté une tondeuse Honda.

Honda garantit votre nouvelle tondeuse contre les défauts et vices cachés pendant une période de 2 ans à compter de la date d'achat (3 mois pour utilisation professionnelle). Cette garantie vient s'ajouter aux droits et à la réglementation de protection des consommateurs, sans en enfreindre ni restreindre l'application. Cependant, si par malchance vous deviez rencontrer un problème avec votre tondeuse, nous vous recommandons de prendre contact avec le magasin où vous avez effectué votre achat. Si votre tondeuse nécessite une intervention sous garantie, vous devrez l'apporter chez un concessionnaire Honda agréé en vous munissant de votre carte de garantie ou d'une preuve d'achat.

### **Bien sûr, certaines conditions s'appliquent à la garantie Honda. Sont exclus de la garantie :**

1. Tous dommages résultant du non respect des révisions périodiques spécifiées par Honda.
2. Tous dommages résultant de réparations ou d'opérations effectuées hors du Réseau de Réparateurs agréés par Honda.
3. Tous dommages résultant d'opérations autres que celles préconisées dans le manuel de l'utilisateur du matériel.
4. Tous dommages résultant de l'utilisation de pièces autres que des pièces d'origine Honda, des lubrifiants et fluides autres que ceux préconisés par Honda, et des accessoires autres que les accessoires approuvés par Honda.
5. Tous dommages ou détériorations résultant de l'écoulement du temps (décoloration naturelle des surfaces peintes ou chromées, écaillage des revêtements ou toute autre détérioration naturelle).
6. Remplacement de pièces d'usure. Honda ne garantit pas la détérioration des pièces due à une usure courante. Les pièces ci-dessous ne sont pas couvertes par la garantie, sauf si leur remplacement est indispensable à la réparation globale sous garantie:
  - Pièces : bougie, filtre à carburant, élément de filtre à air, plaquette de frein, disque d'embrayage, pneu, roue, roulements de roues, corde de démarreur manuel, câble, courroie, lame.
  - Liquides : huile, graisse.
7. Les opérations de nettoyage, réglages et toutes autres opérations de maintenance périodique (nettoyage du carburateur, vidange de l'huile moteur, affûtage des lames, réglages des câbles et courroies).
8. Les frais annexes engendrés par la réclamation sous garantie, incluant :
  - Compensation pour perte de temps, perte commerciale ou coût d'une location d'un matériel de substitution.
  - Coûts du transport aller et retour du matériel chez le concessionnaire.

Tous dommages causés par une exposition du matériel à la suie, la fumée, aux produits chimiques, aux déjections d'oiseaux, à l'eau de mer, au vent marin, au sel ou à tout autre phénomène dû à l'environnement.

## Condiciones De Garantía Honda

Felicidades por la compra de su cortacésped Honda.

Honda le garantiza cualquier defecto de material y la mano de obra por un periodo de 2 años a partir de la fecha de compra (3 meses para uso profesional). Esta garantía no afecta sus derechos establecidos por ley, sino que se añade a ellos.

De todas maneras, en caso de surgir cualquier problema y precisara reparar Su cortacésped en garantía, por favor diríjase al distribuidor a través del cual lo adquirió. Él mismo le aconsejará acerca de cómo proceder y le informará de las condiciones de garantía Honda. Tenga presente que para cualquier reparación en garantía debe llevar su cortacésped a un taller autorizado con el correspondiente carnet de garantía o un justificante de compra.

### **La garantía no cubrirá las siguientes reclamaciones :**

1. Cualquier daño ocasionado por la falta de mantenimiento especificado por Honda.
2. Cualquier daño resultante de una reparación o mantenimiento que no haya sido llevado a cabo por un Servicio Honda autorizado.
3. Cualquier daño ocasionado por un manejo inadecuado y no especificado en el manual de usuario.
4. Cualquier daño ocasionado por el uso de recambio no original, carburantes, aceites y accesorios distintos a los recomendados por Honda.
5. Cualquier daño o deterioro debido al paso del tiempo (decoloración de la pintura, chapa o cualquier otro deterioro natural).
6. Piezas sujetas a desgaste por el uso: Honda no garantiza las piezas deterioradas por el uso. Las piezas aquí detalladas no están cubiertas por la garantía a menos que sean necesarias como piezas en una reparación en garantía :
  - Piezas : bujía, filtro gasolina, filtro aire, ferodos de freno, disco de embrague, neumáticos, rueda, cojinetes de ruedas, cuerda de arranque, cables, correa, cuchilla.
  - Fluidos: Aceite, grasa.
7. Limpieza, ajustes y otras tareas de mantenimiento periódico (limpieza del carburador, cambio de aceite, ajuste de cables y correas, afilar cuchillas).
8. Gastos fortuitos causados por la reparación en garantía, incluidos:
  - Gastos ocasionados por la inmovilización de la máquina.
  - Costes debidos al transporte de la máquina.
9. Cualquier daño resultante de la exposición de la máquina a humo, hollín, productos químicos, brisa marina, agua de mar, sal o cualquier fenómeno ambiental.

## EC Declaration of Conformity

1. The undersigned, Piet Renneboog, on behalf of the authorized representative, herewith declares that the machinery described below fulfils all the relevant provisions of:

- Directive 98/37/EC and 2006/42/EC on machinery
- Directive 2004/108/EC on electromagnetic compatibility
- Directive 2000/14/EC – 2005/88/EC on outdoor noise

2. Description of the machinery

- a) Generic denomination: Lawn mower  
 b) Function: Grass cutting

c) Commercial name	d) Type	e) Serial number
*1	*1	

3. Manufacturer

Honda Power Equipment Mfg., Inc.  
 PO Box 37  
 Honda Drive, NC Hwy 119  
 Swepsonville, NC 27359 USA

4. Authorized representative

Honda Motor Europe Ltd. Aalst Office  
 Wijngaardveld 1 (Noord V),  
 9300 Aalst – BELGIUM

5. References to harmonized standards	6. Other standards or specifications
EN836:1997/A3:2004	-

7. Outdoor noise Directive (50 < L ≤ 70)

- a) Measured sound power : \*1  
 b) Guaranteed sound power : \*1  
 c) Noise parameter : \*1  
 d) Conformity assessment procedure: ANNEX VI  
 e) Notified body: SNCH

11, Route de Luxembourg  
 L – 5230 Sandweiler

8. Done at:

Aalst, BELGIUM

9. Date:

\_\_\_\_\_  
 Piet Renneboog  
 Homologation Manager  
 Honda Motor Europe, Ltd., Aalst Office

French	Italian	German
Déclaration CE de Conformité	Dichiarazione CE di Conformità	EG-Konformitätserklärung
1 Le sous signé, Piet Renneboog, de la part du représentant autorisé, déclare que la machine décrit ci-dessous répond à toutes les dispositions applicables de:  * Directive Machine 98/37/EC, 2006/42/EC * Directive 2004/108/EC sur la compatibilité électromagnétique * Directive 2000/14/EC - 2005/88/EC des émissions sonores dans l'environnement des matériels destinés à être utilisés à l'extérieur des bâtiments	Il sottoscritto, Piet Renneboog, in qualità di rappresentante autorizzato, dichiara qui di seguito che la macchina sotto descritta soddisfa tutte le disposizioni pertinenti delle:  * Direttiva macchina 98/37/CE, 2006/42/CE * Direttiva sulla compatibilità elettromagnetica 2004/108/CE * Direttiva sulla emissione acustica delle macchine e attrezzature destinate a funzionare all'aperto 2000/14/CE - 2005/88/CE	Der Unterzeichner, Piet Renneboog erklärt hiermit im Namen der Bevollmächtigten, dass das hierunter genannte Maschine allen einschlägigen Bestimmungen der * entspricht.  * Maschinenrichtlinie 98/37/EC, 2006/42/EC * Richtlinie der Elektromagnetischen Kompatibilität 2004/108/EC * Geräuschrichtlinie im Freien 2000/14EC - 2005/88/EC
2 Description de la machine a) Denomination générique Tondeuse à gazon b) Fonction Herbe de coupe c) Nom Commercial d) Type e) Numéro de série	Descrizione della macchina a) Denominazione generica Rasaerba b) Funzione Erba taglio c) Denominazione commerciale d) Tipo e) Numero di serie	Beschreibung der Maschine a) Allgemeine Bezeichnung Rasenmäher b) Funktion Schneiden gras c) Handelsbezeichnung d) Typ e) Seriennummer
3 Constructeur	Costruttore	Hersteller
4 Représentant autorisé	Rappresentante Autorizzato	Bevollmächtigter
5 Référence aux normes harmonisées	Riferimento agli standard armonizzati	Verweis auf harmonisierte Normen
6 Autres normes et spécifications	Altri standard o specifiche	Andere Normen oder Spezifikationen
7 Directive des émissions sonores dans l'environnement des matériels destinés à être utilisés à l'extérieur des bâtiments a) Puissance acoustique mesurée b) Puissance acoustique garantie c) Paramètre du bruit d) Procédure d'évaluation de conformité e) Organisme notifié	Direttiva sulla emissione acustica delle macchine e attrezzature destinate a funzionare all'aperto a) Livello di potenza sonora misurato b) Livello di potenza sonora garantito c) Parametri emissione acustica d) Procedura di valutazione della conformità e) Organismo notificato	Geräuschrichtlinie im Freien a) gemessene Lautstärke b) Schalleistungspegel c) Geräuschvorgabe d) Konformitätsbewertungs Ablauf e) Benannte Stelle
8 Fait à	Fatto a	Ort
9 Date	Data	Datum

Dutch	Danish	Greek
EG-verklaring van overeenstemming	EU OVERENSTEMMELSEERKLÆRING	ΕΚ-Δήλωση συμμόρφωσης
1 Ondergetekende, Piet Renneboog, in naam van de gemachtigde van de fabrikant, verklaart hiermee dat het hieronder beschreven machine voldoet aan alle toepasselijke bepalingen van :  * Richtlijn 98/37/EC, 2006/42/EC betreffende machines * Richtlijn 2004/108/EC betreffende elektromagnetische overeenstemming * Richtlijn 2000/14/EC - 2005/88/EC betreffende geluidsemisie (openlucht)	UNDERTEGNEDE, PIET RENNEBOOG, PÅ VEGNE AF DEN AUTORISEREDE REPRÆSENTANT, ERKLÆRER HERMED AT MASKINEN, SOM ER BESKREVET NEDENFOR, OPFYLDER ALLE RELEVANTE BESTEMMELSER IFØLGE:  * MASKINDIREKTIV 98/37/EF, 2006/42/EF * EMC-DIREKTIV 2004/108/EF * DIREKTIV OM STØJEMMISSION 2000/14/EF - 2005/88/EF	Ο καταρτισμένος αρμόδιος Piet Renneboog, εκ μέρους του εξουσιοδοτημένου αντιπροσώπου με το παρών δηλώνω ότι το παρακάτω περιγραφόμενο όχημα πληροί όλες τις σχετικές προδιαγραφές του:  * Οδηγία 98/37/ΕΚ, 2006/42/ΕΚ για μηχανές * Οδηγία 2004/108/ΕΚ για την ηλεκτρομαγνητική συμβατότητα * Οδηγία 2000/14/ΕΚ - 2005/88/ΕΚ για το επίπεδο θορύβου σε εξωτερικούς χώρους.
2 Beschrijving van de machine a) Algemene benaming Gazonmaaiër b) Functie Snijden gras c) Handelsbenaming d) Type e) Serienummer	BESKRIVELSE AF PRODUKTET a) FÆLLESBETEGNELSE Plæneklipperen b) ANVENDELSE Gras snijden c) HANDELSBETEGNELSE d) TYPE e) SERIENUMMER	Περιγραφή a) Γενική ονομασία Μησοκαπτική φρέζα b) Λειτουργία για προπομάσια του εδάφους c) Εμπορική ονομασία d) Τύπος e) Αριθμός σειράς παραγωγής
3 Fabrikant	PRODUCENT	Κατασκευαστής
4 Gemachtigde van de fabrikant	AUTORISERET REPRÆSENTANT	Εξουσιοδοτημένος αντιπρόσωπος
5 Referereert naar geharmoniseerde normen	REFERENCIE TIL HARMONISEREDE STANDARDER	Αναφορά σε αναρμονισμένα πρότυπα
6 Andere normen of specificaties	ANDRE STANDARDER ELLER SPECIFIKATIONER	Λοιπά πρότυπα ή προδιαγραφές
7 Geluidsemisierichtlijn (openlucht) a) Gemeten geluidsvermogensniveau b) Gewaarborgd geluidsvermogensniveau c) Geluidparameter d) Conformiteitsbeoordelingsprocedure e) Aangemelde instantie	DIREKTIV OM STØJEMMISSION FRA MASKINER TIL UDENDØRS BRUG a) MÅLT LYEFFEKTNIVEAU b) GARANTERET LYEFFEKTNIVEAU c) STØJPARAMETER d) PROCEDURE FOR OVERENSSTEMMELSESVURDERING e) BEMYNDIGET ORGAN	Οδηγία επιπέδου θορύβου εξωτερικών χώρων a) Μετρήσιμα ηχητικά ένταση b) Εγγυημένα ηχητικά ένταση c) Ηχητική παράμετρος d) Διαδικασία πιστοποίησης e) Οργανισμός πιστοποίησης
8 Plaats	STED	Η δοκιμή έγινε
9 Datum	DATO	Ημερομηνία

"EC Declaration of Conformity" CONTENT OUTLINE  
 "CE-Déclaration de conformité" DESCRIPTION DE TABLE DES MATIERES  
 "EU-Konformitätserklärung" INHALTSÜBERSICHT  
 DESCRIPCIÓN GENERAL DEL CONTENIDO DE LA "Declaración de Conformidad CE"  
 DESCRIZIONE DEL CONTENUTO DELLA "Dichiarazione CE di Conformità"  
 EG-Verklaring van Overeenstemming" CONTENT SCHEMA

\*1: See specification page      \*1: Consulte la página de las especificaciones      \*1: Vedi la pagina delle caratteristiche tecniche      \*1: Voir page de spécifications  
 \*1: Siehe Spezifikationen-Seite      \*1: Zie specificatie pagina



## Major Honda Distributor Locations

### AUSTRIA

#### Honda Motor Europe (North)

Hondastraße 1  
2351 Wiener Neudorf  
Tel. : +43 (0)2236 690 10  
Fax : +43 (0)2236 690 480  
<http://www.honda.at>

### BALTIC STATES (Estonia/Latvia/Lithuania) Honda Motor Europe Ltd. Estonian Branch

Tulika 15/17  
10613 Tallinn  
Tel. : +372 6801 300  
Fax : +372 6801 301  
E-mail: [honda.baltic@honda-eu.com](mailto:honda.baltic@honda-eu.com)

### BELGIUM Honda Motor Europe (North)

Doomveld 180-184  
1731 Zellik  
Tel. : +32 2620 10 00  
Fax : +32 2620 10 01  
<http://www.honda.be>  
[BH\\_PE@HONDA-EU.COM](mailto:BH_PE@HONDA-EU.COM)

### BULGARIA Kirov Ltd.

49 Tsaritsa Yoana blvd  
1324 Sofia  
Tel. : +359 2 93 30 892  
Fax : +359 2 93 30 814  
<http://www.kirov.net>  
E-mail : [honda@kirov.net](mailto:honda@kirov.net)

### CROATIA Hongoldonia d.o.o.

Jelkovecka Cesta 5  
10360 Sesvete – Zagreb  
Tel. : +385 1 2002053  
Fax : +385 1 2020754  
<http://www.hongoldonia.hr>  
E-mail : [jure@hongoldonia.hr](mailto:jure@hongoldonia.hr)

### CYPRUS

#### Alexander Dimitriou & Sons Ltd.

162, Yiannos Kranidiotis Avenue  
2235 Latsia, Nicosia  
Tel. : +357 22 715 300  
Fax : +357 22 715 400

### CZECH REPUBLIC BG Technik cs, a.s.

U Zavodiste 251/8  
15900 Prague 5 - Velka Chuchle  
Tel. : +420 2 838 70 850  
Fax : +420 2 667 11 45  
<http://www.honda-stroje.cz>

### DENMARK Tima Products A/S

Tårnfalkevej 16  
2650 Hvidovre  
Tel. : +45 36 34 25 50  
Fax : +45 36 77 16 30  
<http://www.tima.dk>

### FINLAND OY Brandt AB.

Tuupakantie 7B  
01740 Vantaa  
Tel. : +358 207757200  
Fax : +358 9 878 5276  
<http://www.brandt.fi>

### FRANCE

#### Honda Relations Clientèle

TSA 80627  
45146 St Jean de la Ruelle Cedex  
Tel. : +33 02 38 81 33 90  
Fax : +33 02 38 81 33 91  
<http://www.honda-fr.com>  
[espaceclient@honda-eu.com](mailto:espaceclient@honda-eu.com)

### GERMANY

#### Honda Motor Europe (North) GmbH

Sprendlinger Landstraße 166  
63069 Offenbach am Main  
Tel. : +49 69 8309-0  
Fax : +49 69 8320 20  
<http://www.honda.de>  
[info@post.honda.de](mailto:info@post.honda.de)

### GREECE

#### General Automotive Co S.A.

71 Leoforos Athinon  
10173 Athens  
Tel. : +30 210 3497809  
Fax : +30 210 3467329  
<http://www.honda.gr>  
[info@saracakis.gr](mailto:info@saracakis.gr)

### HUNGARY

#### Motor Pedo Co Ltd.

Kamaraerdei ut 3.  
2040 Budaors  
Tel. : +36 23 444 971  
Fax : +36 23 444 972  
<http://www.hondakisgepek.hu>  
[info@hondakisgepek.hu](mailto:info@hondakisgepek.hu)

### ICELAND

#### Bernhard ehf.

Vatnagardar 24-26  
104 Reykjavik  
Tel. : +354 520 1100  
Fax : +354 520 1101  
[www.honda.is](http://www.honda.is)

Warranty Booklet only

### IRELAND

#### Two Wheels Ltd

M50 Business Park, Ballymount  
Dublin 12  
Tel. : +353 1 4381900  
Fax : +353 1 4607851  
<http://www.hondaireland.ie>  
[Service@hondaireland.ie](mailto:Service@hondaireland.ie)

### ITALY

#### Honda Italia Industriale S.p.A.

Via della Cecchignola, 5/7  
00143 Roma  
Tel. : +848 846 632  
Fax : +39 065 4928 400  
<http://www.hondaitalia.com>  
[info.power@honda-eu.com](mailto:info.power@honda-eu.com)

### MALTA

#### The Associated Motors Company Ltd.

New Street in San Gwakkim Road  
Mriehel Bypass, Mriehel QRM17  
Tel. : +356 21 498 561  
Fax : +356 21 480 150

### NETHERLANDS

#### Honda Motor Europe (North)

Afd. Power Equipment-Capronilaan 1  
1119 NN Schiphol-Rijk  
Tel. : +31 20 7070000  
Fax : +31 20 7070001  
<http://www.honda.nl>

### NORWAY Berema AS

P.O. Box 454  
1401 Ski  
Tel. : +47 64 86 05 00  
Fax : +47 64 86 05 49  
<http://www.berema.no>  
[berema@berema.no](mailto:berema@berema.no)

### POLAND

#### Aries Power Equipment Sp. z o.o.

ul. Wroclawska 25  
01-493 Warszawa  
Tel. : +48 (22) 861 43 01  
Fax : +48 (22) 861 43 02  
[www.ariespower.pl](http://www.ariespower.pl), [www.mojahonda.pl](http://www.mojahonda.pl)  
[info@ariespower.pl](mailto:info@ariespower.pl)

### PORTUGAL

#### Honda Portugal, S.A.

Rua Fontes Pereira de Melo 16  
Abrunheira, 2714-506 Sintra  
2714-506 Sintra  
Tel. : +351 21 915 53 33  
Fax : +351 21 915 23 54  
<http://www.honda.pt>  
mail: [honda.produtos@honda-eu.com](mailto:honda.produtos@honda-eu.com)

### REPUBLIC OF BELARUS

#### Scanlink Ltd.

Kozlova Drive, 9  
220037 Minsk  
Tel. : +375 172 999090  
Fax : +375 172 999900  
<http://www.hondapower.by>

### ROMANIA

#### Hit Power Motor Srl

Calea Giulesti N° 6-8 - Sector 6  
060274 Bucuresti  
Tel. : +40 21 637 04 58  
Fax : +40 21 637 04 78  
<http://www.honda.ro>  
[hit\\_power@honda.ro](mailto:hit_power@honda.ro)

### RUSSIA

#### Honda Motor RUS LLC

21. MKAD 47 km., Leninsky district.  
Moscow region, 142784 Russia  
Tel. : +7 (495) 745 20 80  
Fax : +7 (495) 745 20 81  
<http://www.honda.co.ru>  
[postoffice@honda.co.ru](mailto:postoffice@honda.co.ru)

### SERBIA & MONTEGEGRO

#### Bazis Grupa d.o.o.

Grcica Milenka 39  
11000 Belgrade  
Tel. : +381 11 3820 295  
Fax : +381 11 3820 296  
<http://www.hondasrbija.co.rs>

### SLOVAK REPUBLIC (SLOVAKIA)

#### Honda Slovakia, spol. s r.o.

Prievozska 6 - 821 09 Bratislava  
Slovak Republic  
Tel. : +421 2 32131112  
Fax : +421 2 32131111  
<http://www.honda.sk>

### SLOVENIA

#### AS Domzale Moto Center D.O.O.

Blatnica 3A  
1236 Trzin  
Tel. : +386 1 562 22 42  
Fax : +386 1 562 37 05  
<http://www.as-domzale-motoc.si>

### SPAIN & LAS PALMAS PROVINCE (Canary Islands) Greens Power Products, S.L.

Avda. Ramon Ciurans, 2  
08530 La Garriga - Barcelona  
Tel. : +34 3 860 50 25  
Fax : +34 3 871 81 80  
<http://www.hondaencasa.com>

### SWEDEN

#### Honda Nordic AB

Box 50583 - Västkustvägen 17  
20215 Malmö  
Tel. : +46 (0)40 600 23 00  
Fax : +46 (0)40 600 23 19  
<http://www.honda.se>  
[hpesinfo@honda-eu.com](mailto:hpesinfo@honda-eu.com)

### SWITZERLAND

#### Honda Suisse S.A.

10, Route des Moulières  
1214 Vernier - Genève  
Tel. : +41 (0)22 939 09 09  
Fax : +41 (0)22 939 09 97  
<http://www.honda.ch>

### TENERIFE PROVINCE (Canary Islands)

#### Automocion Canarias S.A.

Carretera General del Sur, KM. 8,8  
38107 Santa Cruz de Tenerife  
Tel. : +34 (922) 620 617  
Fax : +34 (922) 618 042  
<http://www.aucasa.com>  
e-mail: [ventas@aucasa.com](mailto:ventas@aucasa.com)  
e-mail: [taller@aucasa.com](mailto:taller@aucasa.com)

### TURKEY

#### Anadolu Motor Uretim ve Pazarlama AS

Esentepe mah. Anadolu cad. No:5  
Kartal 34870 Istanbul  
Tel. : +90 216 389 59 60  
Fax : +90 216 353 31 98  
[www.anadolumotor.com.tr](http://www.anadolumotor.com.tr)  
[antor@antor.com.tr](mailto:antor@antor.com.tr)

### UKRAINE

#### Honda Ukraine LLC

101 Volodymyrska Str. - Build. 2  
Kyiv 01033  
Tel. : +380 44 390 14 14  
Fax : +380 44 390 14 10  
<http://www.honda.ua>  
[CR@honda.ua](mailto:CR@honda.ua)

### UNITED KINGDOM

#### Honda (UK) Power Equipment

470 London Road  
Slough - Berkshire, SL3 8QY  
Tel. : +44 (0)845 200 8000

Website : [www.honda.co.uk](http://www.honda.co.uk)

**HONDA**  
The Power of Dreams