



Solenoid valve 2/2 way N.O. With pilot control

21W3ZB190
÷
21W7ZB500

PRESENTATION:

S.V. with pilot control for interception of fluids compatible with the construction materials.

A minimum operational pressure of 0,2 bar is required.

The materials used and the tests carried out ensure maximum reliability and duration.

USE: Automation
Heating

PIPES: G 3/4 - G 2

COILS: 8W - Ø 13
BDA - BSA 155°C (class F)
BDV 180°C (class H)

**COIL HOUSING AND COIL FORMER MATERIAL ARE
MADE BY 100% VIRGIN MATERIAL.**

Max. allowable pressure (PS)

G 3/4 - G 1 25 bar

G 1 1/4 - G 2 16 bar

Ambient temperature:

See coils catalogue page for its compatibility.



Gaskets	Temperature	Medium
B =NBR (nitrile rubber)	- 10°C + 90°C	Air, inert gas, water
E =EPDM (ethylene-propylene)	- 10°C +140°C	Water, low pressure steam
V =FKM (fluoroelastomer)	- 10°C +140°C	Mineral oils (2°E), gasoline gas oil

For seals other than NBR replace the letter "B" with the ones corresponding to the other seals. E.I. 21W5ZE350.

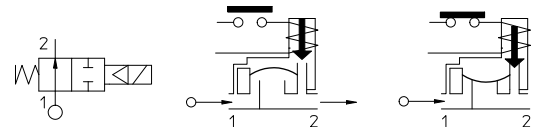

Pipe ISO 228/1	Code	Max viscosity		Ø mm	Kv l/mn	Power watt	Pressure		
		cSt	°E				min bar	M.O.P.D. AC bar DC bar	
G 3/4	21W3ZB190	12	~ 2	19	140	8	0,2	16	16
G 1	21W4ZB250			25	190				
G 1 1/4	21W5ZB350			35	400				
G 1 1/2	21W6ZB400			40	520				
G 2	21W7ZB500			50	750				



CE Approval

(Pressure Equipment Directive 97/23/CE)

for S.V. 21W5+21W7

The "ODE" reserves the right to carry out technical and aesthetic modifications without prior notification.

MATERIALS:

Body	Brass - UNI EN 12165 CW617N
Armature tube	Stainless steel AISI series 300
Fixed core	Stainless steel AISI series 400
Plunger	Stainless steel AISI series 400
Phase displacement ring	Copper - Cu 99,9%
Spring	Stainless steel AISI series 300
Seal	Standard: B=NBR On request: E=EPDM V=FKM
Orifice	Brass - UNI EN 12165 CW617N

On request:

Connector	Pg 9 or Pg 11
Connector conformity	ISO 4400

FEATURES:

Electrical conformity	IEC 335
Protection degree	IP 65 EN 60529 (DIN 40050) with coil fitted by connector.

SPARE PARTS:

1. Coil:		6. Complete diaphragm:	
See coils list		G 3/4-G 1	Code R450431/B
2. Complete diaphragm support:		G 1 1/4-G 1 1/2	Code R450466/B
Code R450788/B		G 2	Code R450432/B

3. Complete armature tube without gasket:	
Code R450573	

4. Gasket O-Ring:	
Code R990000/B	

5. Gasket O-Ring:	
G 3/4-G 1	Code R990002/B
G 1 1/4-G 1 1/2	Code R990005/B
G 2	Code R990081/B

KIT:

KT130ZB30-F=2+3+4

MAINTENANCE KIT:

G 3/4 - G 1
KTG0W3ZB19=2+5+6
G 1 1/4 - G 1 1/2
KTG0W5ZB35=2+5+6
G 2
KTG0W7ZB50=2+5+6

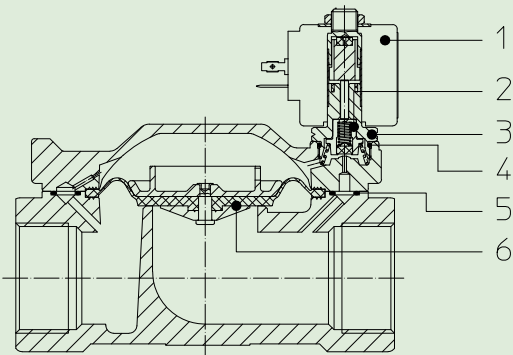

DIMENSIONS:

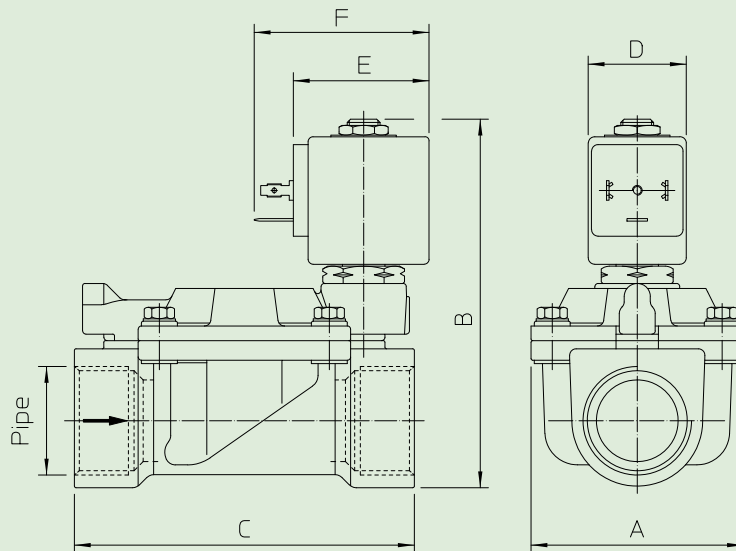

Type	Pipe ISO 228/1	A mm	B mm	C mm
21W3ZB190	G 3/4	65	105	104
21W4ZB250	G 1		112	
21W5ZB350	G 1 1/4	98	125	144
21W6ZB400	G 1 1/2			
21W7ZB500	G 2	118	141	172

COIL TYPE	POWER ABSORPTION			DIMENSIONS		
	W ---	Hold VA ~	Inrush VA ~	D mm	E mm	F mm
B	8	14,5	25	30	42	54